

# MOUNTING AND OPERATING INSTRUCTIONS



**EB 8384-0 EN (1300-1609)**

**Translation of original instructions**



**Type 3730-0 Electropneumatic Positioner**



## Note on these mounting and operating instructions

These mounting and operating instructions assist you in mounting and operating the device safely. The instructions are binding for handling SAMSON devices.

- For the safe and proper use of these instructions, read them carefully and keep them for later reference.
- If you have any questions about these instructions, contact SAMSON's After-sales Service Department (aftersaleservice@samson.de).



The mounting and operating instructions for the devices are included in the scope of delivery. The latest documentation is available on our website at [www.samson.de](http://www.samson.de) > **Service & Support** > **Downloads** > **Documentation**.

## Definition of signal words

### **DANGER**

*Hazardous situations which, if not avoided, will result in death or serious injury*

### **WARNING**

*Hazardous situations which, if not avoided, could result in death or serious injury*

### **NOTICE**

*Property damage message or malfunction*

### **Note**

*Additional information*

### **Tip**

*Recommended action*

<b>1</b>	<b>Safety instructions and measures</b> .....	<b>5</b>
1.1	Notes on possible severe personal injury .....	8
1.2	Notes on possible property damage .....	8
<b>2</b>	<b>Markings on the device</b> .....	<b>10</b>
2.1	Nameplate .....	10
2.2	Article code .....	11
<b>3</b>	<b>Design and principle of operation</b> .....	<b>12</b>
3.1	Mounting versions .....	13
3.2	Device overview and operating controls .....	13
3.3	Accessories .....	14
3.4	Travel tables .....	17
3.5	Technical data .....	18
3.6	Dimensions in mm .....	21
<b>4</b>	<b>Measures for preparation</b> .....	<b>24</b>
4.1	Unpacking .....	24
4.2	Transporting .....	24
4.3	Storage .....	24
<b>5</b>	<b>Mounting and start-up</b> .....	<b>26</b>
5.1	Mounting position .....	26
5.2	Lever and pin position .....	26
5.3	Direct attachment .....	28
5.3.1	Type 3277-5 Actuator .....	28
5.3.2	Type 3277 Actuator .....	30
5.4	Attachment according to IEC 60534-6 .....	32
5.5	Attachment according to VDI/VDE 3847-1 .....	34
5.6	Attachment to Type 3510 Micro-flow Valve .....	40
5.7	Reversing amplifier for double-acting actuators .....	42
5.7.1	Reversing amplifier (1079-1118 or 1079-1119) .....	42
5.8	Attaching positioners with stainless steel housings .....	44
5.9	Air purging function for single-acting actuators .....	44
5.10	Setting start-up parameters .....	45
5.10.1	Fail-safe position .....	45
5.10.2	Volume restriction Q .....	46
5.10.3	Travel selection .....	46
5.10.4	Direction of action .....	46
5.10.5	Signal pressure limitation .....	47
5.10.6	Set point .....	47

## Contents

5.11	Pneumatic connections.....	48
5.11.1	Signal pressure connection .....	49
5.11.2	Signal pressure gauges .....	49
5.11.3	Supply pressure .....	49
5.11.4	Signal pressure (output).....	49
5.12	Electrical connections .....	50
<b>6</b>	<b>Operation .....</b>	<b>53</b>
<b>7</b>	<b>Operating the positioner.....</b>	<b>54</b>
7.1	Setting zero .....	54
7.2	Reducing gain .....	54
7.3	Adapting the travel .....	54
7.4	Activate tight-closing function.....	54
<b>8</b>	<b>Servicing.....</b>	<b>55</b>
8.1	Preparation for return shipment.....	55
<b>9</b>	<b>Malfunctions .....</b>	<b>55</b>
9.1	Emergency action .....	56
<b>10</b>	<b>Decommissioning and removal .....</b>	<b>56</b>
10.1	Decommissioning.....	56
10.2	Removing the positioner .....	56
10.3	Disposal.....	56
<b>11</b>	<b>Appendix.....</b>	<b>57</b>
11.1	After-sales service .....	57
11.2	Certificates .....	57



# 1 Safety instructions and measures

## Intended use

The SAMSON Type 3730-0 Positioner is mounted on pneumatic control valves and is used to assign the valve position to the control signal. The device is designed to operate under exactly defined conditions (e.g. operating pressure, temperature). Therefore, operators must ensure that the positioner is only used in applications where the operating conditions correspond to the technical data. In case operators intend to use the positioner in other applications or conditions than specified, contact SAMSON.

SAMSON does not assume any liability for damage resulting from the failure to use the device for its intended purpose or for damage caused by external forces or any other external factors.

➔ Refer to the technical data for limits and fields of application as well as possible uses.

## Reasonably foreseeable misuse

The Type 3730-0 Positioner is **not** suitable for the following applications:

- Use outside the limits defined during sizing and by the technical data

Furthermore, the following activities do not comply with the intended use:

- Use of non-original spare parts
- Performing maintenance activities not specified by SAMSON

## Qualifications of operating personnel

The positioner is to be mounted, started up or operated only by trained and experienced personnel familiar with the product. According to these mounting and operating instructions, trained personnel refers to individuals who are able to judge the work they are assigned to and recognize possible hazards due to their specialized training, their knowledge and experience as well as their knowledge of the applicable standards.

Explosion-protected versions of this device are to be operated only by personnel who has undergone special training or instructions or who is authorized to work on explosion-protected devices in hazardous areas.

## Safety instructions and measures

### Personal protective equipment

No personal protective equipment is required for the direct handling of the positioner. Work on the control valve may be necessary when mounting or removing the device.

- Observe the requirements for personal protective equipment specified in the valve documentation.
- Check with the plant operator for details on further protective equipment.

### Revisions and other modifications

Revisions, conversions or other modifications of the product are not authorized by SAMSON. They are performed at the user's own risk and may lead to safety hazards, for example. Furthermore, the product may no longer meet the requirements for its intended use.

### Safety features

Upon failure of the air supply or electric signal, the positioner vents the actuator, causing the valve to move to the fail-safe position determined by the actuator.

### Warning against residual hazards

The positioner has direct influence on the control valve. Any hazards that could be caused in the valve by the process medium, the signal pressure or by moving parts are to be prevented by taking appropriate precautions. They must observe all hazard statements, warning and caution notes in these mounting and operating instructions, especially for installation, start-up and service work.

If inadmissible motions or forces are produced in the pneumatic actuator as a result of the supply pressure level, it must be restricted using a suitable supply pressure reducing station.

### Explosion protection

- Explosive dust atmospheres of zone 21 or zone 22

The following applies to type of protection Ex i in combustible dust atmospheres:

If intrinsic safety is impaired by the influence of dust, an enclosure complying with Clause 6.1.3 of EN 60079-11 with at least in degree of protection IP 5X must be used.

The requirements according to Clause 6.1.3 apply to the cable glands accordingly. The degree of ingress protection is verified by a test according to IEC 60529 and EN 60079-0 (e.g. performed by VDE).

For use in the presence of combustible dust in compliance with type of protection Ex tb IIC (protection by enclosure), observe Clause 5.6.3 of EN 60079-14.

- Servicing explosion-protected devices

If a part of the device on which the explosion protection is based needs to be serviced, the device must not be put back into operation until a qualified inspector has assessed it according to explosion protection requirements, has issued an inspection certificate, or given the device a mark of conformity. Inspection by a qualified inspector is not required if the manufacturer performed a routine test on the device before putting it back into operation. Document the passing of the routine test by attaching a mark of conformity to the device.

Replace explosion-protected components only with original, routine-tested components by the manufacturer.

Devices that have already been used outside hazardous areas and are intended for future use inside hazardous areas must comply with the safety requirements placed on serviced devices. Before being operated inside hazardous areas, test the devices according to the specifications for servicing explosion-protected devices.

EN 60079-17 applies to servicing explosion-protected devices.

- Maintenance, calibration and work on equipment

To ensure that components relevant to explosion protection are not damaged, observe the maximum permissible values specified in the certificates for intrinsically safe circuit.

### **Responsibilities of the operator**

The operator is responsible for proper operation and compliance with the safety regulations. Operators are obliged to provide these mounting and operating instructions to the operating personnel and to instruct them in proper operation. Furthermore, the operator must ensure that operating personnel or third persons are not exposed to any danger.

### **Responsibilities of operating personnel**

Operating personnel must read and understand these mounting and operating instructions as well as the specified hazard statements, warning and caution notes. Furthermore, the operating personnel must be familiar with the applicable health, safety and accident prevention regulations and comply with them.

### **Referenced standards and regulations**

The device with a CE marking fulfills the requirements of the Directives 2014/30/EU and 2011/65/EU as well as 2014/34/EU depending on the version. The declarations of conformity are included at the end of these instructions.

### Referenced documentation

The following documents apply in addition to these mounting and operating instructions:

- The mounting and operating instructions of the components on which the positioner is mounted (valve, actuator, valve accessories, etc.).

## 1.1 Notes on possible severe personal injury

### DANGER

#### **Risk of fatal injury due to the formation of an explosive atmosphere.**

Incorrect installation, operation or maintenance of the positioner in potentially explosive atmospheres may lead to ignition of the atmosphere and cause death.

- The following regulations apply to installation in hazardous areas: EN 60079-14 (VDE 0165, Part 1).
- Installation, operation or maintenance of the positioner must only be performed by personnel who has undergone special training or instructions or who is authorized to work on explosion-protected devices in hazardous areas.

## 1.2 Notes on possible property damage

### NOTICE

#### **Risk of damage to the positioner due to incorrect mounting position.**

- Do not mount the positioner with the back of the device facing upward.

#### **Risk of malfunction due to incorrect sequence during start-up.**

The positioner can only work properly if the mounting and start-up are performed in the prescribed sequence.

- Perform mounting and start-up as described in section 5 in page 26.

#### **An incorrect electrical power supply will damage the positioner.**

A current source must be used to provide the electrical power for the positioner.

- Only use a current source and never a voltage source.

**Incorrect assignment of the terminals will damage the positioner and will lead to malfunction.**

For the positioner to function properly, the prescribed terminal assignment must be observed.

- Connect the electrical wiring to the positioner according to the prescribed terminal assignment.

**Risk of positioner damage due to incorrect grounding of the electric welding equipment.**

- Do not ground electric welding equipment near to the positioner.

## 2 Markings on the device

### 2.1 Nameplate

#### Explosion-protected version

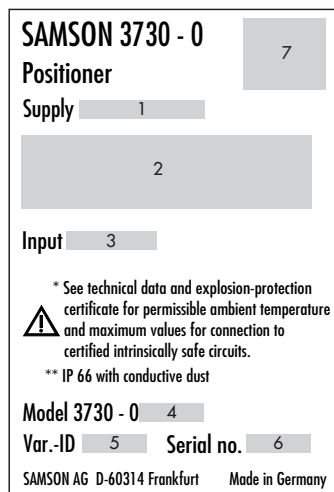

#### Version without explosion protection

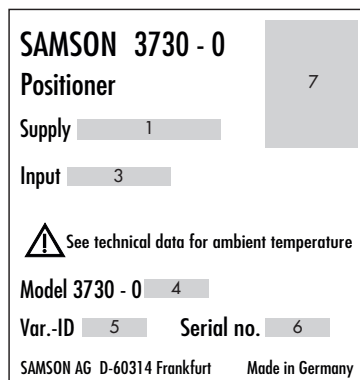

- 1 Supply pressure
- 2 Type of protection for explosion-protected devices
- 3 Signal range
- 4 Model no.

- 5 Configuration ID
- 6 Serial number
- 7 Compliance

## 2.2 Article code

Positioner	Type	3730-0	x	0	0	0	0	0	0	0	0	x	0	0	x	x	
<b>Explosion protection</b>																	
Without																	
<b>ATEX:</b> II 2G Ex ia IIC T6 Gb, II 2D Ex ia IIIC T80°C Db																	
<b>FM/CSA:</b> Class I, Zone 0 AEx ia IIC; Class I, II, III, Div.1, Groups A-G; Class I, Div.2, Groups A-D; Class II, Div.2, Groups F, G/ Ex ia IIC T6; Class I, Zone 0; Class II, Groups E-G; Ex nA II T6; Class I, Zone 2; Class II, Div. 2, Groups E-G																	
<b>ATEX:</b> II 2D Ex tb IIIC T80°C Db IP66																	
<b>JIS:</b> Ex ia IIC T6																	
<b>ATEX:</b> II 3G Ex nA II T6; II 3G Ex ic IIC T6; II 3D Ex tc IIIC T80°C IP66																	
<b>Housing material</b>																	
Aluminum																	
Stainless steel																	
<b>Special applications</b>																	
Without																	
Compatible with paint																	
Exhaust air with ¼ NPT connection, back of housing sealed																	
<b>Special version</b>																	
Without																	
<b>EAC Ex:</b> 1Ex ia IIC T6/T5/T4 Gb X, Ex tb IIIC T 80°C Db X																	
<b>EAC Ex:</b> 2Ex nA IIC T6/T5/T4 Gc X, 2Ex ic IIC T6/T5/T4 Gc X, Ex tc IIIC T 80°C Dc X																	
Attachment according to VDI/VDE 3847 including interface																	
Attachment according to VDI/VDE 3847 prepared for interface																	

### 3 Design and principle of operation

→ Refer to Fig. 1

The electropneumatic positioner is mounted on pneumatic control valves and is used to assign the valve position (controlled variable  $x$ ) to the control signal (set point  $w$ ). The positioner compares the electric control signal to the travel of the control valve and issues a signal pressure (output variable  $y$ ) for the pneumatic actuator.

A supply pressure between 1.4 to 6 bar is required. The electric input signal is a set point between 4 to 20 mA.

The positioner is designed depending on which accessories are selected either for direct attachment to SAMSON Type 3277 Actuators or for attachment to actuators according to NAMUR (IEC 60534-6).

The positioner consists of a travel sensor system proportional to resistance, an analog i/p converter with a downstream air capacity booster and the electronics with microcontroller.

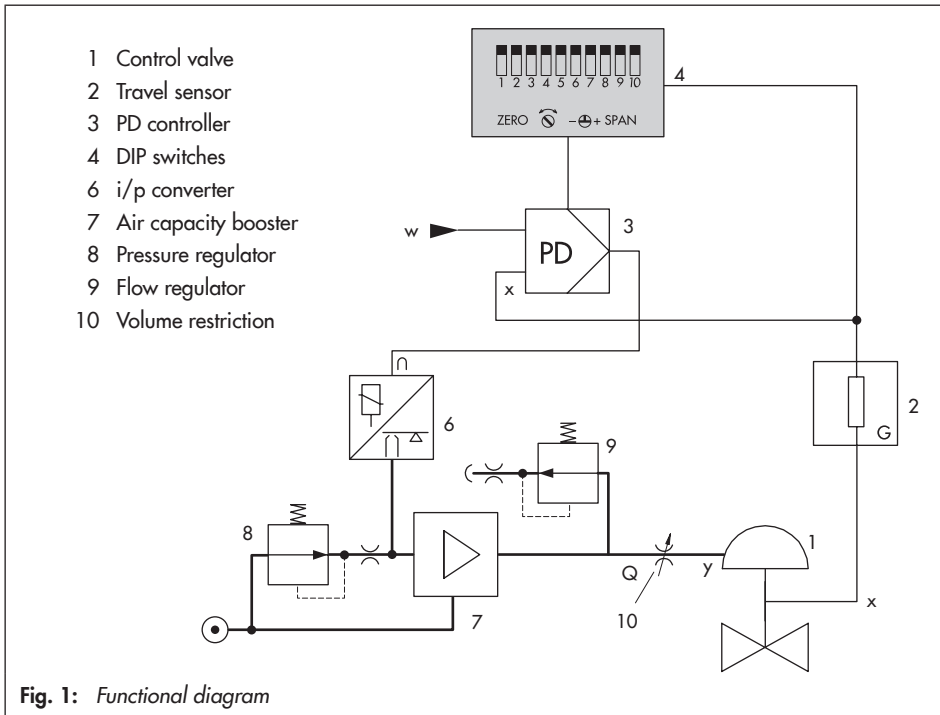



The position of the valve stem is transmitted as a linear travel motion over the pick-up lever to the travel sensor (2) and supplied to an analog PD controller (3). The PD controller compares this actual value to the DC control signal coming from the control system, e.g. a 4 to 20 mA signal.

In case of a system deviation, the activation of the i/p module (6) is changed so that the actuator of the control valve (1) is pressurized or vented accordingly over the downstream booster (7). This causes the valve plug to move to the position determined by the set point.

The supply air is supplied to the booster (7) and the pressure regulator (8). An intermediate flow regulator (9) with fixed settings is used to purge the positioner and, at the same time, guarantees trouble-free operation of the booster. The output signal pressure supplied by the booster can be limited by enabling the DIP switch setting **S5**.

The volume restriction (10) and the switch **S6** are used to optimize the positioner by adapting it to the actuator size and changing the gain factor.

#### **Tight-closing function:**

After activating the tight-closing function (see section 7.4), the pneumatic actuator is completely filled with air or vented as soon as the set point falls below or exceeds the corresponding deactivating point of 4.5 mA or 19.5 mA.

In the case of three-way valves, the function allows the plug move to the end position with full actuator thrust.

## **3.1 Mounting versions**

The Type 3730-0 Positioner is suitable for the following types of attachment using the corresponding accessories (see section 3.3):

- Direct attachment to Type 3277 Actuator (see section 5.3): The positioner is mounted on the yoke. The signal pressure is connected to the actuator over a connection block: internally over a hole in the valve yoke for "actuator stem extends" fail-safe action and through an external signal pressure line for "actuator stem retracts" fail-safe action.
- Attachment to actuators according to IEC 60534-6 (see section 5.4): The positioner is mounted to the control valve using a NAMUR bracket.
- Attachment according to VDI/VDE 3847-1 (see section 5.5): Attachment according to VDI/VDE 3847-1/-2 using the corresponding accessories allows the positioner to be replaced quickly while the process is running.
- Attachment to Type 3510 Micro-flow Valve (see section 5.6): The positioner is attached to the valve yoke using a bracket.

## **3.2 Device overview and operating controls**

See section 6 on page 53.

### 3.3 Accessories

**Table 1:** *General accessories*

Designation		Order no.
Reversing amplifier for double-acting actuators		Type 3710
Cable gland M20x1.5	Black plastic (6 to 12 mm clamping range)	8808-1011
	Blue plastic (6 to 12 mm clamping range)	8808-1012
	Nickel-plated brass (6 to 12 mm clamping range)	1890-4875
	Nickel-plated brass (10 to 14 mm clamping range)	1992-8395
	Stainless steel 1.4305 (8 to 14.5 mm clamping range)	8808-0160
Adapter M20x1.5 to ½ NPT	Powder-coated aluminum	0310-2149
	Stainless steel	1400-7114
Lever	S	0510-0522
	M	0510-0510
	L	0510-0511
	XL	0510-0512
	XXL	0510-0525
Cover plate with list of parameters and operating instructions	DE/EN (delivered state)	1990-3528
	EN/ES	1990-5769
	EN/FR	1990-5768

**Table 2:** *Direct attachment to Type 3277-5 (see section 5.3.1)*

Designation		Order no.	
Mounting parts	Standard version for actuators 120 cm <sup>2</sup> or smaller	1400-7452	
	Version compatible with paint for actuators 120 cm <sup>2</sup> or smaller	1402-0940	
Accessories for actuator	Old switchover plate for Type 3277-5xxxxxx. <b>00</b> Actuator (old)	1400-6819	
	New switchover plate for Type 3277-5xxxxxx. <b>01</b> Actuator (new) <sup>1)</sup>	1400-6822	
	New connecting plate for Type 3277-5xxxxxx. <b>01</b> Actuator (new) <sup>1)</sup> , G ¼ and ½ NPT	1400-6823	
	Old connecting plate for Type 3277-5xxxxxx. <b>00</b> Actuator (old): G ¼	1400-6820	
	Old connecting plate for Type 3277-5xxxxxx. <b>00</b> (old): ½ NPT	1400-6821	
Accessories for positioner	Connecting plate (6)	G ¼	1400-7461
		¼ NPT	1400-7462
	Pressure gauge bracket (7)	G ¼	1400-7458
		¼ NPT	1400-7459
	Pressure gauge mounting kit (8) up to max. 6 bar (output/supply)	Stainless steel/brass	1400-6950
		Stainless steel/stainless steel	1400-6951

<sup>1)</sup> Only new switchover and connecting plates can be used with new actuators (Index 01). Old and new plates are not interchangeable.

**Table 3:** Direct attachment to Type 3277 (see section 5.3.2)

Mounting parts/accessories		Order no.
Standard version for actuators 175, 240, 350, 355, 700, 750 cm <sup>2</sup>		1400-7453
Version compatible with paint for actuators 175, 240, 350, 355, 700, 750 cm <sup>2</sup>		1402-0941
Connection block with seals and screw	G ¼	1400-8819
	¼ NPT	1402-0901
Pressure gauge mounting kit up to max. 6 bar (output/supply)	Stainless steel/brass	1400-6950
	Stainless steel/stainless steel	1400-6951
Piping with screw fittings <sup>1)</sup>		Order no.
Actuator (175 cm <sup>2</sup> ), steel	G ¼/G ¾	1402-0970
	¼ NPT/¾ NPT	1402-0976
Actuator (175 cm <sup>2</sup> ), stainless steel	G ¼/G ¾	1402-0971
	¼ NPT/¾ NPT	1402-0978
Actuator (240 cm <sup>2</sup> ), steel	G ¼/G ¾	1400-6444
	¼ NPT/¾ NPT	1402-0911
Actuator (240 cm <sup>2</sup> ), stainless steel	G ¼/G ¾	1400-6445
	¼ NPT/¾ NPT	1402-0912
Actuator (350 cm <sup>2</sup> ), steel	G ¼/G ¾	1400-6446
	¼ NPT/¾ NPT	1402-0913
Actuator (350 cm <sup>2</sup> ), stainless steel	G ¼/G ¾	1400-6447
	¼ NPT/¾ NPT	1402-0914
Actuator (355 cm <sup>2</sup> ), steel	G ¼/G ¾	1402-0972
	¼ NPT/¾ NPT	1402-0979
Actuator (355 cm <sup>2</sup> ), stainless steel	G ¼/G ¾	1402-0973
	¼ NPT/¾ NPT	1402-0980
Actuator (700 cm <sup>2</sup> ), steel	G ¼/G ¾	1400-6448
	¼ NPT/¾ NPT	1402-0915
Actuator (700 cm <sup>2</sup> ), stainless steel	G ¼/G ¾	1400-6449
	¼ NPT/¾ NPT	1402-0916
Actuator (750 cm <sup>2</sup> ), steel	G ¼/G ¾	1402-0974
	¼ NPT/¾ NPT	1402-0981
Actuator (750 cm <sup>2</sup> ), stainless steel	G ¼/G ¾	1402-0975
	¼ NPT/¾ NPT	1402-0982

<sup>1)</sup> For "actuator stem retracts" direction of action;  
with air purging of the top diaphragm chamber;  
air purging of the diaphragm chamber for "actuator stem extends" direction of action

## Design and principle of operation

**Table 4:** Attachment to NAMUR rib or attachment to rod-type yokes<sup>1)</sup> according to IEC 60534-6 (section 5.4)

Travel in mm	Lever	For actuator	Order no.
7.5	S	Type 3271-5 with 60/120 cm <sup>2</sup> on Type 3510 Micro-flow Valve	1402-0478
5 to 50	M <sup>2)</sup>	Actuators from other manufacturers and Type 3271 with 120 to 750 cm <sup>2</sup> effective areas	1400-7454
14 to 100	L	Actuators from other manufacturers and Type 3271 with 1000 and 1400-60 cm <sup>2</sup>	1400-7455
30 or 60	L	Type 3271, 1400-120 and 2800 cm <sup>2</sup> versions with 30/60 mm travel <sup>3)</sup>	1400-7466
		Mounting brackets for Emerson and Masoneilan linear actuators (in addition, a mounting kit according to IEC 60534-6 is required depending on the travel). See rows above.	1400-6771
		Valtek Type 25/50	1400-9554
40 to 200	XL	Actuators from other manufacturers and Type 3271 with 1400-120 and 2800 cm <sup>2</sup> and with 120 mm travel	1400-7456
Accessories			Order no.
Connecting plate	G ¼		1400-7461
	¼ NPT		1400-7462
Pressure gauge bracket	G ¼		1400-7458
	¼ NPT		1400-7459
Pressure gauge mounting kit up to max. 6 bar (output/supply)	Stainless steel/brass		1400-6950
	Stainless steel/stainless steel		1400-6951

<sup>1)</sup> 20 to 35 mm rod diameter

<sup>2)</sup> M lever is mounted on basic device (included in the scope of delivery)

<sup>3)</sup> In conjunction with Type 3273 Side-mounted Handwheel with 120 mm rated travel, additionally one bracket (0300-1162) and two countersunk screws (8330-0919) are required.

**Table 5:** Attachment according to VDI/VDE 3847-1 (see section 5.5)

Mounting parts	Order no.
VDI/VDE 3847 interface adapter	1402-0257
Mounting kit for attachment to SAMSON Type 3277 Actuator with 175 to 750 cm <sup>2</sup>	1402-0868
Mounting kit for attachment to SAMSON Type 3271 Actuator or non-SAMSON actuators	1402-0869
Travel pick-off for valve travel up to 100 mm	1402-0177
Travel pick-off for 100 to 200 mm valve travel (SAMSON Type 3271 Actuator only)	1402-0178

### 3.4 Travel tables

#### **i** Note

The **M** lever is included in the scope of delivery.

**S**, **L**, **XL** levers for attachment according to IEC 60534-6 (NAMUR) are available as accessories (see Table 4 on page 16). The **XXL** lever is available on request.

**Table 6:** Direct attachment to Type 3277-5 and Type 3277 Actuator

Actuator size [cm <sup>2</sup> ]	Rated travel [mm]	Adjustment range at positioner Travel [mm]	Required lever	Assigned pin position
120	7.5	5.0 to 25.0	M	25
120/175/240/350	15	7.0 to 35.0	M	35
355/700/750	30	10.0 to 50.0	M	50

**Table 7:** Attachment according to IEC 60534-6 (NAMUR)

SAMSON valves with Type 3271 Actuator		Other valves/actuators		Required lever	Assigned pin position
Actuator area [cm <sup>2</sup> ]	Rated travel [mm]	Min. travel [mm]	Max. travel [mm]		
60 and 120 with Type 3510 Valve	7.5	3.6	18.0	S	17
120	7.5	5.0	25.0	M	25
120/175/240/350	15	7.0	35.0	M	35
355/700/750	7.5				
355/700/750	15 and 30	10.0	50.0	M	50
1000/1400/2800	30	14.0	52.0	L	70
	60	20.0	75.0	L	100
1400/2800	120	40.0	200.0	XL	200
See manufacturer's specifications	200	See manufacturer's specifications		XXL	300

### 3.5 Technical data



**Table 8:** Type 3730-0 Electropneumatic Positioner

Type 3730-0 Positioner: the technical data for the explosion-protected devices may be restricted by the limits specified in the test certificates.	
Rated travel	Adjustable: Direct attachment to Type 3277: 5.3 to 30 mm Attachment according to IEC 60534-6: 5.3 to 200 mm
Travel range	Adjustable within the rated travel, max. ratio 1:5
Set point w	4 to 20 mA signal range Split-range operation 4 to 12 mA and 12 to 20 mA, selected at the DIP switch Two-wire device, reverse polarity protection, static destruction limit 100 mA
Minimum current	> 3.6 mA
Load impedance	Version without explosion protection: $\leq 6$ V (corresponding to 300 $\Omega$ at 20 mA) Explosion-protected version: $\leq 6$ V
Supply air Air quality acc. to ISO 8573-1 (edition 2001-02):	1.4 to 7 bar (20 to 105 psi) Max. particle size and density: Class 4 Oil content: Class 3 · Pressure dew point: Class 3 or at least 10 K below the lowest ambient temperature to be expected
Signal pressure (output)	0 bar up to the supply pressure Limitation to approx. 2.4 bar enabled by setting DIP switch
Characteristic	Linear, deviation from characteristic $\leq 1$ %
Hysteresis	$\leq 1$ %
Sensitivity	$\leq 0.1$ %
Direction of action	Selectable over DIP switch
Air consumption, steady state	Independent from supply pressure approx. 120 $l_n/h$
Air output capacity To fill actuator with air To vent actuator	At $\Delta p = 6$ bar: 8.5 $m_n^3/h$ · At $\Delta p = 1.4$ bar: 3.0 $m_n^3/h$ · $K_{Vmax(20^\circ C)} = 0.09$ At $\Delta p = 6$ bar: 14.0 $m_n^3/h$ · At $\Delta p = 1.4$ bar: 4.5 $m_n^3/h$ · $K_{Vmax(20^\circ C)} = 0.15$
Permissible ambient temperature	-20 to +80 °C -45 to +80 °C with metal cable gland The temperature limits for the explosion-protected devices may be restricted by the limits specified in the test certificates.
Influences	Temperature: $\leq 0.15$ %/10 K Supply air: none Vibrations: $\leq 0.25$ % up to 2000 Hz and 4 g according to IEC 770
Electromagnetic compatibility	Complying with EN 61000-6-2, EN 61000-6-3, EN 61326-1 and NAMUR Recommendation NE 21

<p>Type 3730-0 Positioner: <b>the technical data for the explosion-protected devices may be restricted by the limits specified in the test certificates.</b></p>	
Use in safety-instrumented systems acc. to IEC 61508	<p>Suitable for use in safety-instrumented systems up to SIL 2 (single device) and SIL 3 (with redundant configuration)                      Emergency shutdown at a set point of 0 mA</p>
Degree of protection	IP 66
Materials	<p>Die-cast aluminum EN AC-ALSi12(Fe) (EN AC-44300) according to DIN EN 1706, chromated and plastic coated                      External parts: stainless steel 1.4404/316L</p>
Weight	Approx. 1 kg
Compliance	

## Design and principle of operation

**Table 9:** *Explosion protection certificates*

Type	Certification	Type of protection/comments
0	Number ZETC/15/2018	0Ex ia IIC T6X 2Ex s II T6 X
	STCC Date 2018-04-27	
	Valid until 2021-04-26	
-01	 1) Number PTB 03.ATEX 2099	II 2G Ex ia IIC T6 Gb, II 2D Ex ia IIIC T80°C Db
	ERC Ex Date 2018-11-30	
-03	Number RU C-DE. AA87.B.01278	1 Ex ia IIC T6/T5/T4 Gb X Ex tb IIIC T80°C Db X
	CSA Date 2018-11-30	
	Valid until 2023-11-29	
-05	Number 1613095	Ex ia IIC T6; Class I, Zone 0 Class II, Groups E, F, G Ex nA II T6; Class I, Zone 2 Class II, Div. 2, Groups E, F, G
	CSA Date 2005-02-11	
-07	Number 3021579	Class I, Zone 0 AEx ia IIC Class I, II, III, Div.1, Groups A, B, C, D, E, F, G Class I, Div.2, Groups A, B, C, D Class II, Div.2, Groups F, G
	FM Date 2004-12-01	
-08	Number PTB 03.ATEX 2099	II 2D Ex tb IIIC T80°C Db IP66
	 1) Date 2016-04-19	
-08	Number TC17330	Ex ia IIC T6
	JIS Date 2017-07-29	
	Valid until 2020-07-28	
-08	Number PTB 03.ATEX 2179 X	II 3G Ex nA II T6 II 3G Ex ic IIC T6 II 3D Ex tc IIIC T80°C IP66
	 2) Date 2013-09-17	
	ERC Ex Date 2018-11-30	
-08	Number RU C DE.08.B.01278	2 Ex nA IIC T6/T5/T4 Gc X 2 Ex ic IIC T6/T5/T4 Gc X Ex tc IIIC T80°C Dc X
	ERC Ex Date 2018-11-30	
-08	Number RU C DE.08.B.01278	2 Ex nA IIC T6/T5/T4 Gc X 2 Ex ic IIC T6/T5/T4 Gc X Ex tc IIIC T80°C Dc X
	ERC Ex Date 2018-11-30	
-08	Number RU C DE.08.B.01278	2 Ex nA IIC T6/T5/T4 Gc X 2 Ex ic IIC T6/T5/T4 Gc X Ex tc IIIC T80°C Dc X
	ERC Ex Date 2018-11-30	

1) EC type examination certificate

2) Statement of conformity



### 3.6 Dimensions in mm

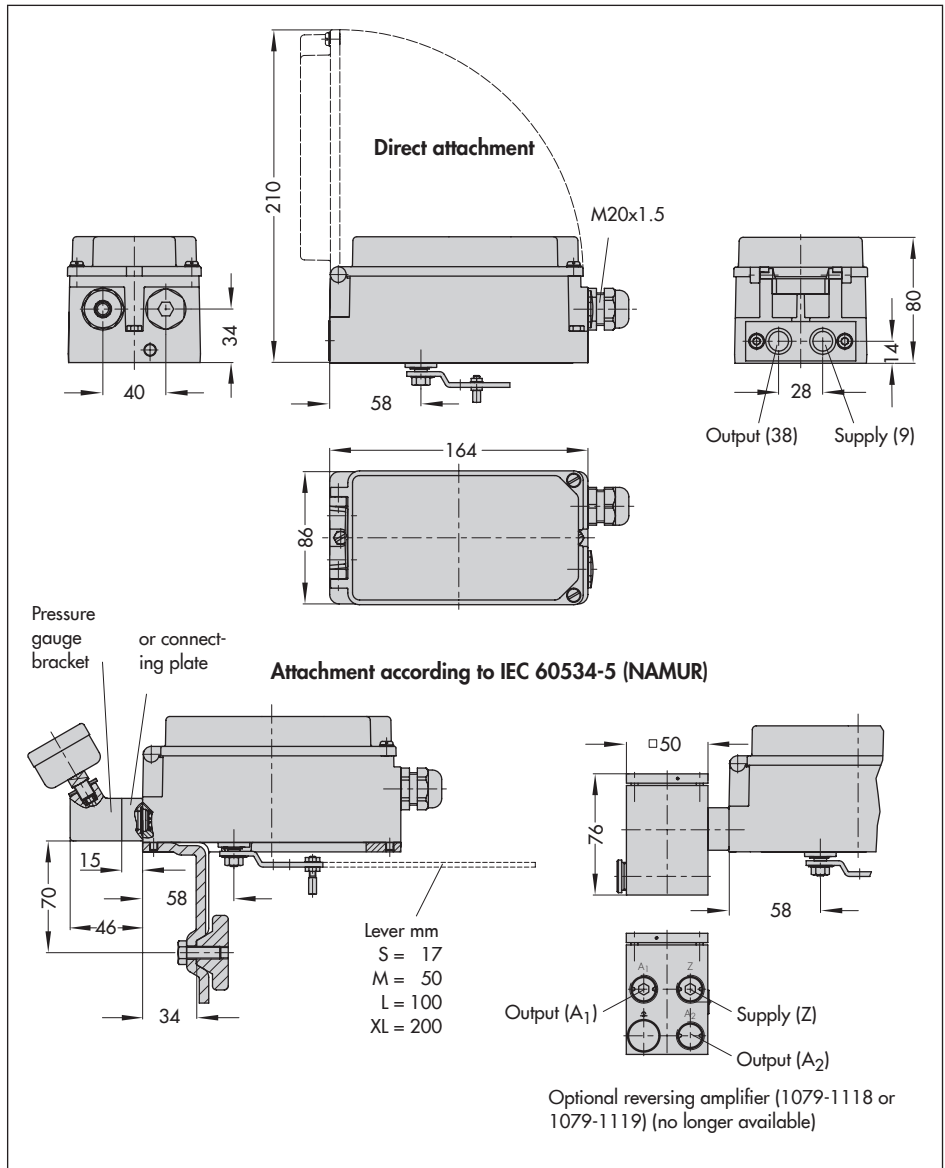

Attachment according to  
VDI/VDE 3847 to Type 3277

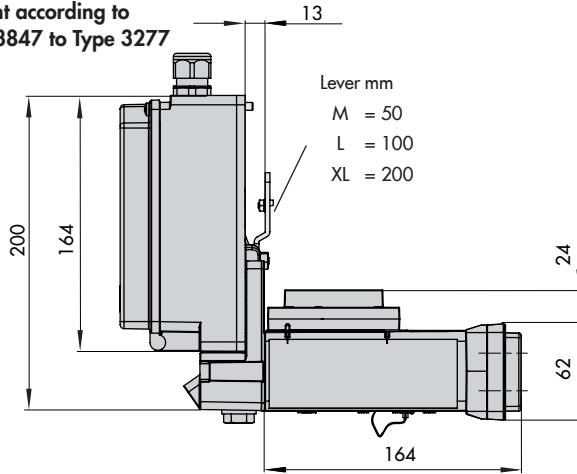

Attachment according to  
VDI/VDE 3847 to a NAMUR  
rib

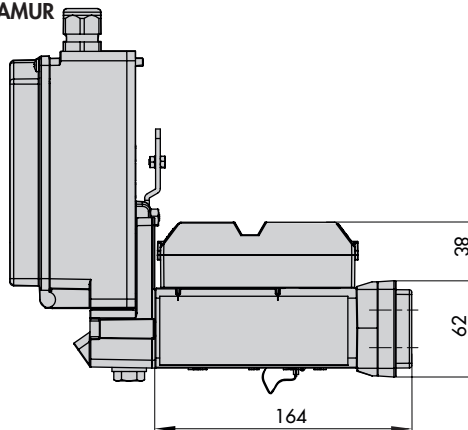

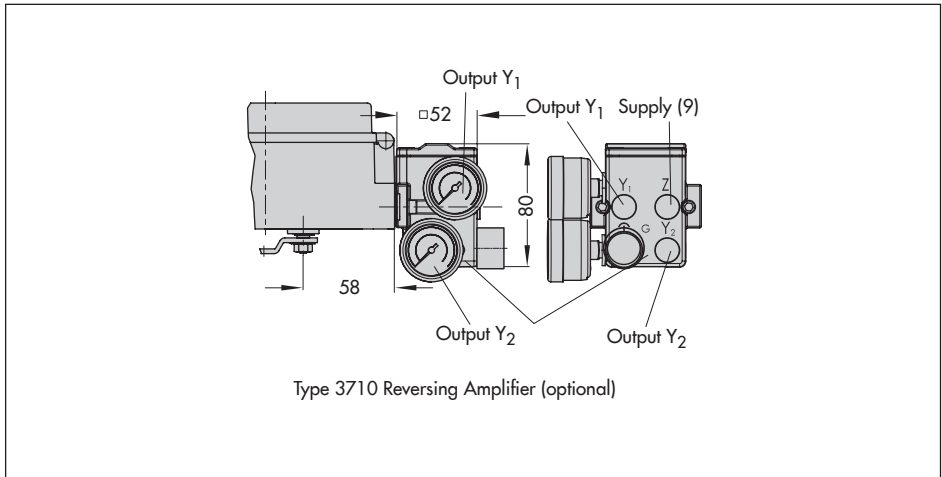

### 4 Measures for preparation

After receiving the shipment, proceed as follows:

1. Check the scope of delivery. Compare the shipment received with the delivery note.
2. Check the shipment for transportation damage. Report any transportation damage.

#### 4.1 Unpacking

##### **NOTICE**

*Risk of positioner damage due to foreign particles entering it.*

*Do not remove the packaging and protective film/protective caps until immediately before mounting and start-up.*

1. Remove the packaging from the positioner.
2. Dispose of the packaging in accordance with the valid regulations.

#### 4.2 Transporting

- Protect the positioner against external influences (e.g. impact).
- Protect the positioner against moisture and dirt.
- Observe transport temperature depending on the permissible ambient temperature (see technical data in section 3.5).

### 4.3 Storage

##### **NOTICE**

*Risk of positioner damage due to improper storage.*

- *Observe the storage instructions.*
- *Contact SAMSON in case of different storage conditions or long storage periods.*

##### **Storage instructions**

- Protect the positioner against external influences (e.g. impact, shocks, vibration).
- Do not damage the corrosion protection (coating).
- Protect the positioner against moisture and dirt. In damp spaces, prevent condensation. If necessary, use a drying agent or heating.
- Observe storage temperature depending on the permissible ambient temperature (see technical data in section 3.5).
- Store positioner with closed cover.
- Seal the pneumatic and electrical connections.



### 5 Mounting and start-up

---

#### **NOTICE**

*Risk of malfunction due to incorrect sequence of mounting, installation and start-up. Observe the prescribed sequence.*

---

→ Sequence:

**1. Remove the protective caps from the pneumatic connections.**

**2. Mount the positioner on the valve.**

→ Section 5.3 onward

**3. Set start-up parameters.**

→ Section 5.10 onward

**4. Perform pneumatic installation.**

→ Section 5.11 onward

**5. Perform electrical installation.**

→ Section 5.12 onward

**6. Perform settings.**

→ Section 6 onward

### 5.1 Mounting position

---

#### **NOTICE**

*Risk of damage to the positioner due to incorrect mounting position.*

*– Do not mount the positioner with the back of the device facing upward.*

*– Do not seal or restrict the vent opening when the device is installed on site.*

---

→ Observe mounting position (see Fig. 3).

### 5.2 Lever and pin position

The positioner is adapted to the actuator and to the rated travel by the lever on the back of the positioner and the pin inserted into the lever.

The travel tables on page 17 show the maximum adjustment range at the positioner. The travel that can be implemented at the valve is additionally restricted by the selected fail-safe position and the required compression of the actuator springs.

The positioner is equipped with the M lever (pin position 35) as standard (see Fig. 4).

---

#### **Note**

*The M lever is included in the scope of delivery.*

*S, L, XL levers are available as accessories (see Table 4 on page 16). The XXL lever is available on request.*

---

If a pin position other than position **35** with the standard **M** lever is required or an **L** or **XL** lever size is required, proceed as follows (see Fig. 5):

1. Fasten the follower pin (2) in the assigned lever hole (pin position as specified in the travel tables on page 17). Only use the longer follower pin included in the mounting kit.
2. Place the lever (1) on the shaft of the positioner and fasten it tight using the disk spring (1.2) and nut (1.1).

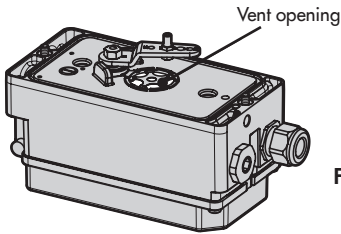

**Fig. 2:** Vent opening  
(back of the positioner)

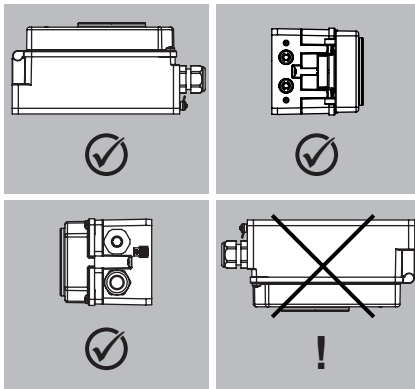

**Fig. 3:** Permissible mounting  
positions

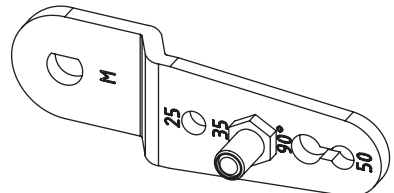

**Fig. 4:** M lever with pin position 35

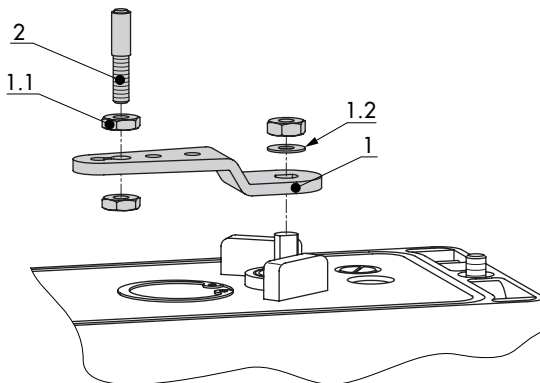

- 1 Lever
- 1.1 Nut
- 1.2 Disk spring
- 2 Follower pin

**Fig. 5:** Mounting the lever  
and follower pin

### 5.3 Direct attachment

#### 5.3.1 Type 3277-5 Actuator

→ Required mounting parts and accessories: Table 2 on page 14.

→ Observe travel tables on page 17.

##### Actuator with 120 cm<sup>2</sup> (see Fig. 6)

Depending on the type of positioner attachment, the signal pressure is routed either left or right of the yoke through a hole to the actuator diaphragm. Depending on the fail-safe action of the actuator "actuator stem extends" or "actuator stem retracts" (valve closes or opens upon supply air failure), the switchover plate (9) must first be attached to the actuator yoke. Align the switchover plate with the corresponding symbol for left or right attachment according to the marking (view looking onto the switchover plate).

1. Mount connecting plate (6) or pressure gauge bracket (7) with pressure gauges on the positioner, making sure the two seals (6.1) are seated properly.
2. Remove screw plug (4) on the back of the positioner and seal the signal pressure output (38) on the connecting plate (6) or on the pressure gauge bracket (7) with the stopper (5) included in the accessories.
3. Place follower clamp (3) on the actuator stem, align it and screw tight so that the mounting screw is located in the groove of the actuator stem.

4. Mount cover plate (10) with narrow side of the cut-out (Fig. 6, on the left) pointing towards the signal pressure connection. Make sure that the gasket (14) points towards the actuator yoke.

5. **15 mm travel:** Keep the follower pin (2) on the **M** lever (1) on the back of the positioner in the pin position **35** (delivered state).

**7.5 mm travel:** Remove the follower pin (2) from the pin position **35**, reposition it in the hole for pin position **25** and screw tight.

6. Insert formed seal (15) into the groove of the positioner housing and insert the seal (10.1) on the back of the housing.
7. Place positioner on the cover plate (10) in such a manner that the follower pin (2) rests on the top of the follower clamp (3). Adjust the lever (1) correspondingly and open the positioner cover to hold the positioner shaft in position at the cap or switch (Fig. 18). The lever (1) must rest on the follower clamp with spring force. Mount the positioner on the cover plate (10) using the two fixing screws.

---

#### **i** Note

*The following applies to all types of attachment except for direct attachment to Type 3277-5: the signal pressure output at the back must be sealed by the screw plug (4, order no. 0180-1436) and the associated O-ring (order no. 0520-0412) (delivered state, parts included in the scope of delivery).*

---



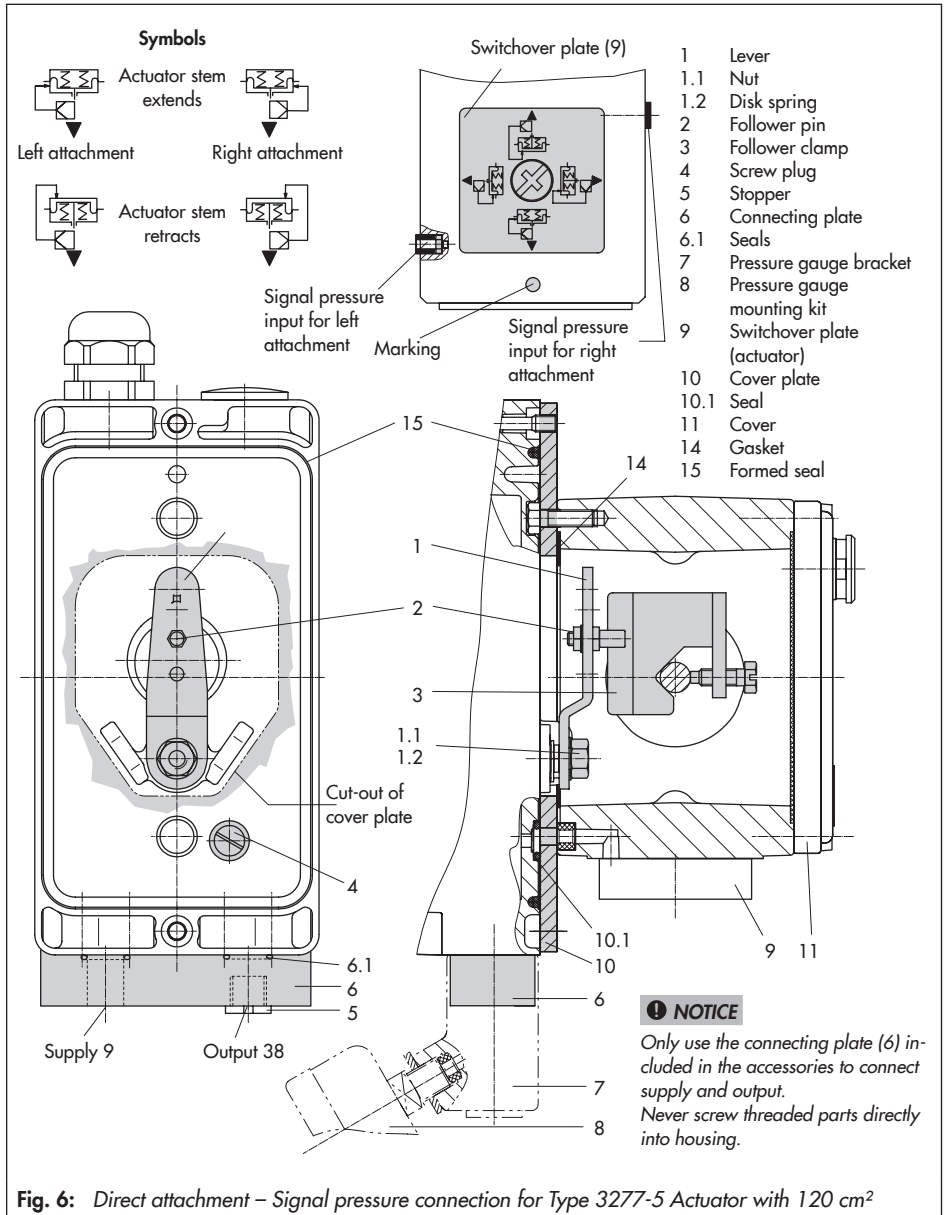

Fig. 6: Direct attachment – Signal pressure connection for Type 3277-5 Actuator with 120 cm<sup>2</sup>

## Mounting and start-up

8. Mount cover (11) on the other side.  
Make sure that the vent plug is located at the bottom when the control valve is installed to allow any condensed water that collects to drain off.

### 5.3.2 Type 3277 Actuator

- ➔ Required mounting parts and accessories: Table 3 on page 15.
- ➔ Observe travel tables on page 17.

#### Actuators with 175 to 750 cm<sup>2</sup> effective areas (see Fig. 7)

Mount the positioner on the yoke. The signal pressure is routed to the actuator over the connection block (12), for actuators with fail-safe action "actuator stem extends" internally through a hole in the valve yoke and for "actuator stem retracts" through an external pipe.

1. Place follower clamp (3) on the actuator stem, align it and screw tight so that the mounting screw is located in the groove of the actuator stem.
2. Mount cover plate (10) with narrow side of the cut-out (Fig. 7, on the left) pointing towards the signal pressure connection. Make sure that the gasket (14) points towards the actuator yoke.
3. For actuators with 355, 700 or 750 cm<sup>2</sup>, remove the follower pin (2) on the **M** lever (1) on the back of the positioner from pin position **35**, reposition it in the hole for pin position **50** and screw tight.

For actuators 175, 240 and 350 cm<sup>2</sup> with 15 mm travel, keep the follower pin (2) in pin position **35**.

4. Insert formed seal (15) into the groove of the positioner housing.
5. Place positioner on the cover plate in such a manner that the follower pin (2) rests on the top of the follower clamp (3). Adjust the lever (1) correspondingly and open the positioner cover to hold the positioner shaft in position at the cap or switch (Fig. 18). The lever (1) must rest on the follower clamp with spring force. Mount the positioner on the cover plate (10) using the two fixing screws.
6. Make sure that the tip of the gasket (16) projecting from the side of the connection block is positioned to match the actuator symbol for the actuator's fail-safe action "actuator stem extends" or "actuator stem retracts". If this is not the case, unscrew the three fastening screws and lift off the cover. Turn the gasket (16) by 180° and re-insert it.  
The old connection block version (Fig. 7, bottom) requires the switch plate (13) to be turned to align the actuator symbol with the arrow marking.
7. Place the connection block (12) with the associated seals against the positioner and the actuator yoke and fasten using the screw (12.1). For actuators with fail-safe action "actuator stem retracts", additionally remove the stopper (12.2) and mount the external signal pressure pipe.
8. Mount cover (11) on the other side.  
Make sure that the vent plug is located at

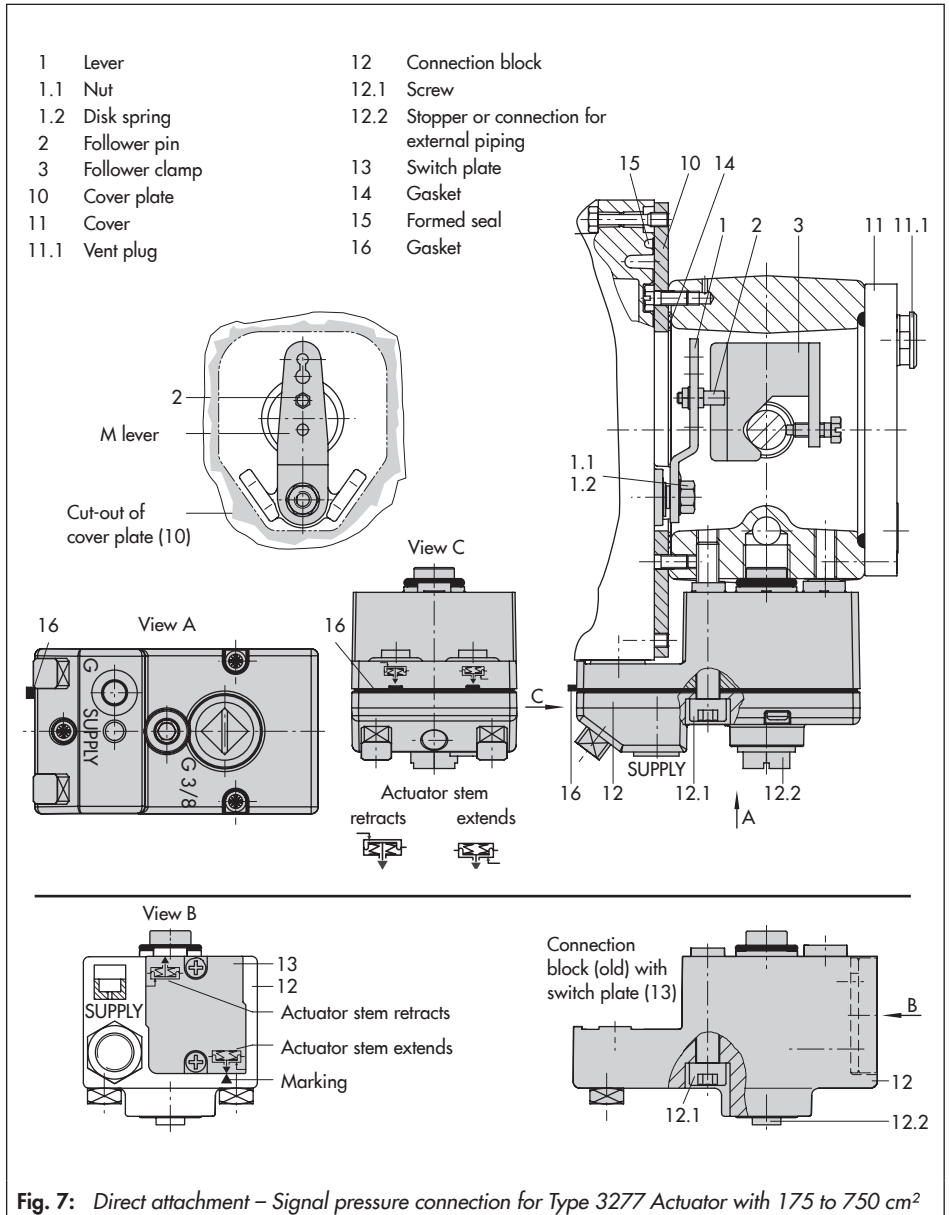

## Mounting and start-up

the bottom when the control valve is installed to allow any condensed water that collects to drain off.

### 5.4 Attachment according to IEC 60534-6

- Required mounting parts and accessories: Table 4 on page 16.
- Observe travel tables on page 17.
- Refer to Fig. 8

The positioner is attached to the control valve using a NAMUR bracket (10).

1. Screw the two bolts (14) to the bracket (9.1) of the stem connector (9), place the follower plate (3) on top and use the screws (14.1) for fastening.

#### **2800 and 1400 cm<sup>2</sup> with 120 mm travel:**

- For a travel of 60 mm or smaller, screw the longer follower plate (3.1) directly to the stem connector (9).
  - For a travel exceeding 60 mm, mount the bracket (16) first and then the follower plate (3) to the bracket together with the bolts (14) and screws (14.1).
2. Mount NAMUR bracket (10) to the control valve as follows:
    - For **attachment to the NAMUR rib**, use an M8 screw (11) and toothed lock washer directly in the yoke hole.
    - For attachment to **valves with rod-type yokes**, use two U-bolts (15) around the yoke. Align the NAMUR bracket (10) according to the em-

bossed scale so that the follower plate (3) is shifted by half the angle range to the NAMUR bracket (the slot of the follower plate is centrally aligned with the NAMUR bracket at mid valve travel).

3. Mount connecting plate (6) or pressure gauge bracket (7) with pressure gauges on the positioner, making sure the two seals (6.1) are seated properly.
4. Select required lever size (1) M, L or XL and pin position according to the actuator size and valve travel listed in the travel table on page 17.

Should a pin position other than position **35** with the standard **M** lever be required or an **L** or **XL** lever size be required, proceed as follows:

5. Fasten the follower pin (2) in the assigned lever hole (pin position as specified in the travel table). Only use the longer follower pin (2) included in the mounting kit.
6. Place the lever (1) on the shaft of the positioner and fasten it tight using the disk spring (1.2) and nut (1.1). Move lever once all the way as far as it will go in both directions.
7. Place positioner on the NAMUR bracket in such a manner that the follower pin (2) rests in the slot of the follower plate (3, 3.1). Adjust the lever (1) correspondingly.  
Screw the positioner to the NAMUR bracket using its two fastening screws.

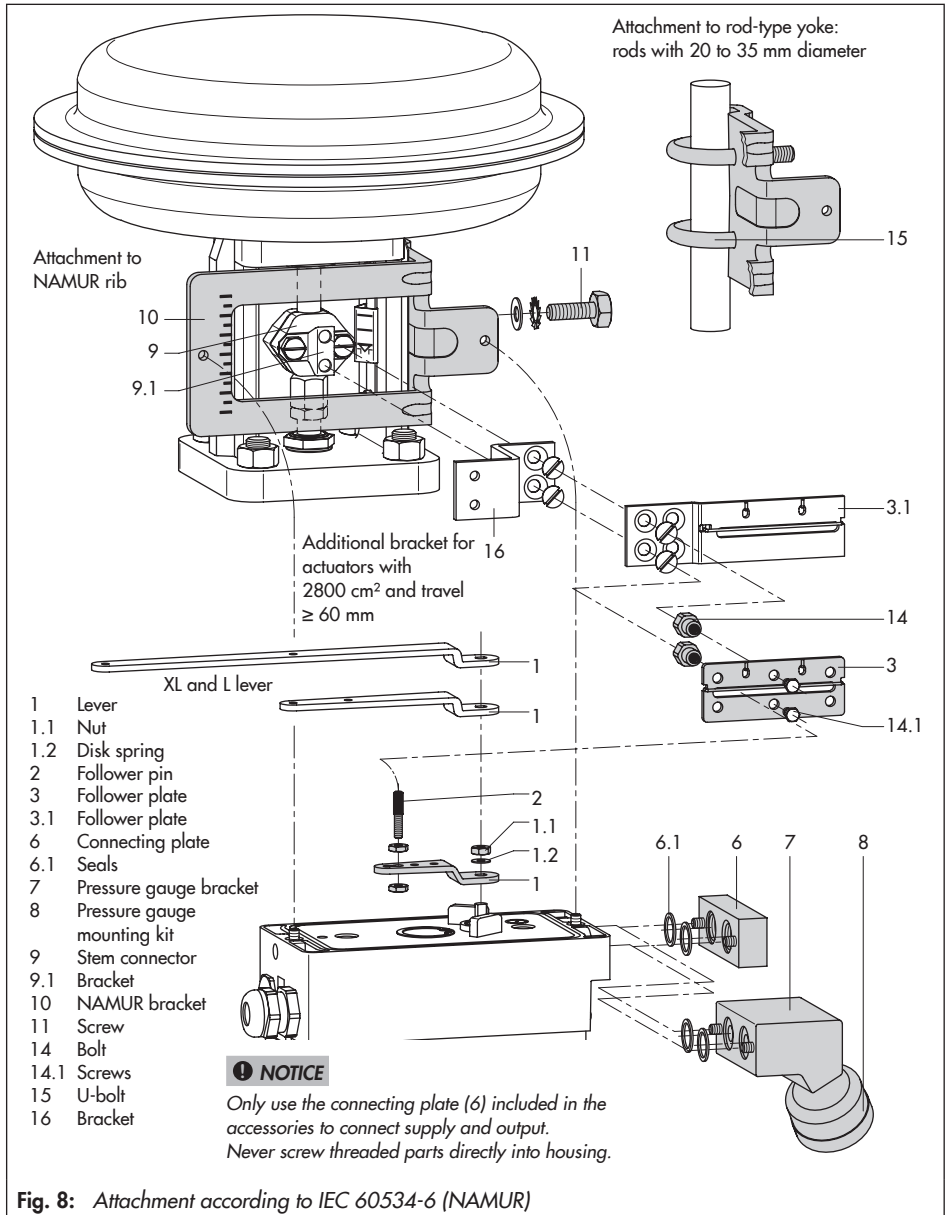

Fig. 8: Attachment according to IEC 60534-6 (NAMUR)

### 5.5 Attachment according to VDI/VDE 3847-1

→ Refer to Fig. 9

The following positioners with air purging of the actuator's spring chamber can be attached according to VDI/VDE 3847:

- Type 3730-0xx0000000x006000
- Type 3730-0xx0000000x007000

The Type 3730-1xx0000000x000000 Positioner without air purging of the actuator's spring chamber can be attached according to VDI/VDE 3847.

This type of attachment allows the positioner to be replaced quickly while the process is running by blocking the air in the actuator.

The signal pressure can be blocked in the actuator by unscrewing the red retaining screw (20) and turning the air blocker (19) on the bottom of the adapter block.

#### Attachment to Type 3277 Actuator (see Fig. 9)

→ Required mounting parts and accessories: Table 5 on page 16

Mount the positioner on the yoke as shown in Fig. 9. The signal pressure is routed to the actuator over the connecting plate (12), for actuators with fail-safe action "actuator stem extends" internally through a bore in the valve yoke and for "actuator stem retracts" through external piping.

Only the Y1 port is required for positioner attachment. The Y2 port can be used for air purging of the spring chamber.

1. Place follower clamp (3) on the actuator stem, align it and screw tight so that the mounting screw is located in the groove of the actuator stem.
2. Place the adapter bracket (6) on the positioner and mount using the screws (6.1). Make sure that the seals are correctly seated. For positioners **with air purging**, remove the stopper (5) before mounting the positioner. For positioners **without air purging**, replace the screw plug (4) with a vent plug.
3. For actuators with 355, 700 or 750 cm<sup>2</sup>, remove the follower pin (2) on the M lever (1) on the back of the positioner from pin position 35, reposition it in the hole for pin position 50 and screw tight.  
For actuators 175, 240 and 350 cm<sup>2</sup> with 15 mm travel, keep the follower pin (2) in pin position 35.
4. Insert the formed seal (6.2) in the groove of the adapter bracket (6).
5. Insert the formed seal (17.1) into the turnboard (17) and mount the turnboard to the adapter block (13) using the screws (17.2).
6. Mount the blank plate (18) to the turnboard (17) using the screws (18.1). Make sure that the seals are correctly seated.

---

#### **i** Note

*A solenoid valve can also be mounted in place of the blank plate (18). The orientation of the turnboard (17) determines the mounting position of the solenoid valve. Alterna-*

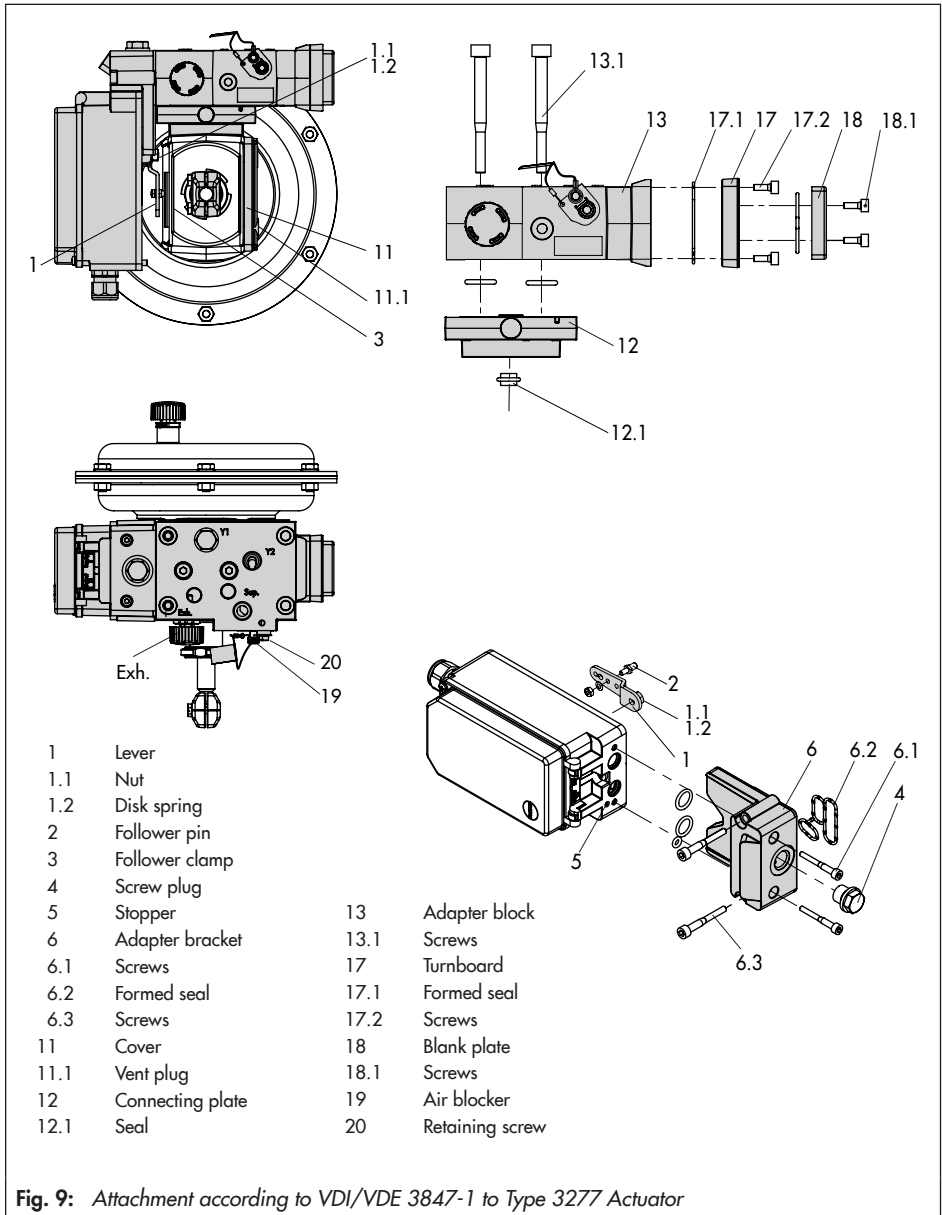

Fig. 9: Attachment according to VDI/VDE 3847-1 to Type 3277 Actuator

## Mounting and start-up

tively, a restrictor plate can be mounted  
▶ AB 11).

7. Insert the screws (13.1) through the middle holes of the adapter block (13).
8. Place the connecting plate (12) together with the seal (12.1) onto the screws (13.1) corresponding to the fail-safe action "actuator stem extends" or "actuator stem retracts". The fail-safe action that applies is determined by aligning the groove of the adapter block (13) with the groove of the connecting plate (12) (Fig. 10).
9. Mount the adapter block (13) together with the connecting plate (12) to the actuator using the screws (13.1).
10. Insert the vent plug (11.1) into the **Exh.** connection.
11. For fail-safe action "actuator stem extends", seal the Y1 port with a blanking plug.

For fail-safe action "actuator stem retracts", connect the Y1 port to the signal pressure connection of the actuator.

Place positioner on the adapter block (13) in such a manner that the follower pin (2) rests on the top of the follower clamp (3). Adjust the lever (1) correspondingly and open the positioner cover to hold the positioner shaft in position at the cap or rotary pushbutton.

The lever (1) must rest on the follower clamp with spring force.

Fasten the positioner to the adapter block (13) using the two fastening screws (6.3). Make sure the formed seal (6.2) is properly seated.

12. Mount cover (11) on the other side to the yoke. Make sure that the vent plug is located at the bottom when the control valve is installed to allow any condensed water that collects to drain off.

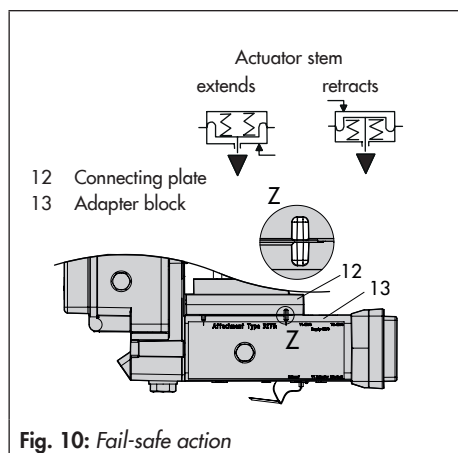



**Attachment to NAMUR rib (see Fig. 11)**

- Required mounting parts and accessories: Table 5 on page 16
- Observe travel tables on page 17.

1. **Series 240 Valves, actuator size up to 1400-60 cm<sup>2</sup>:** Screw the two bolts (14) to the bracket of the stem connector or directly to the stem connector (depending on the version), place the follower plate (3) on top and use the screws (14.1) to fasten it.

**Type 3251 Valve, 350 to 2800 cm<sup>2</sup>:**

Screw the longer follower plate (3.1) to the bracket of the stem connector or directly to the stem connector (depending on the version).

**Type 3254 Valve, 1400-120 to 2800 cm<sup>2</sup>:**

Screw the two bolts (14) to the bracket (16). Fasten the bracket (16) onto the stem connector, place the follower plate (3) on top and use the screws (14.1) to fasten it.

Mount the positioner on the NAMUR rib as shown in Fig. 11.

2. For **attachment to the NAMUR rib**, fasten the NAMUR connection block (10) directly into the existing yoke bore using the screw and toothed lock washer (11). Align the marking on the NAMUR valve connection (on the side marked '1') to 50 % travel.

For attachment to **valves with rod-type yokes** using the formed plate (15), which is placed around the yoke: screw the four studs into the NAMUR connection block (10). Place the NAMUR connection block

on the rod and position the formed plate (15) on the opposite side. Use the nuts and toothed lock washers to fasten the formed plate onto the studs. Align the marking on the NAMUR valve connection (on the side marked '1') to 50 % travel.

3. Place the adapter bracket (6) on the positioner and mount using the screws (6.1). Make sure that the seals are correctly seated. For positioners **with air purging**, remove the stopper (5) before mounting the positioner. For positioners **without air purging**, replace the screw plug (4) with a vent plug.
4. Select required lever size (1) M, L or XL and pin position according to the actuator size and valve travel listed in the travel table on page 17.

Should a pin position other than position 35 with the standard M lever be required or an L or XL lever size be required, proceed as follows:

- Fasten the follower pin (2) in the assigned lever hole (pin position as specified in the travel table). Only use the longer follower pin (2) included in the mounting kit.
  - Place the lever (1) on the shaft of the positioner and fasten it tight using the disk spring (1.2) and nut (1.1).
  - Move lever once all the way as far as it will go in both directions.
5. Insert the formed seal (6.2) in the groove of the adapter bracket.

## Mounting and start-up

6. Insert the formed seal (17.1) into the turnboard (17) and mount the turnboard to the adapter block (13) using the screws (17.2).
7. Mount the blank plate (18) to the turnboard using the screws (18.1). Make sure that the seals are correctly seated.

nection of the actuator. Seal the Y2 port with a blanking plug.

For **double-acting actuators and actuators with air purging**, connect the Y2 port of the adapter block to the signal pressure connection of the second actuator chamber or spring chamber of the actuator.

---

### **i** Note

*A solenoid valve can also be mounted in place of the blank plate (18). The orientation of the turnboard (17) determines the mounting position of the solenoid valve. Alternatively, a restrictor plate can be mounted (► AB 11).*

---

8. Fasten the adapter block (13) to the NAMUR connection block using the screws (13.1).
9. Insert the vent plug into the Exh. connection.
10. Place the positioner on the adapter block (13) in such a manner that the follower pin (2) rests on the top of the follower plate (3, 3.1). Adjust the lever (1) correspondingly.  
Fasten the positioner to the adapter block (13) using the two fastening screws (6.3). Make sure the formed seal (6.2) is properly seated.
11. For **single-acting actuators without air purging**, connect the Y1 port of the adapter block to the signal pressure con-

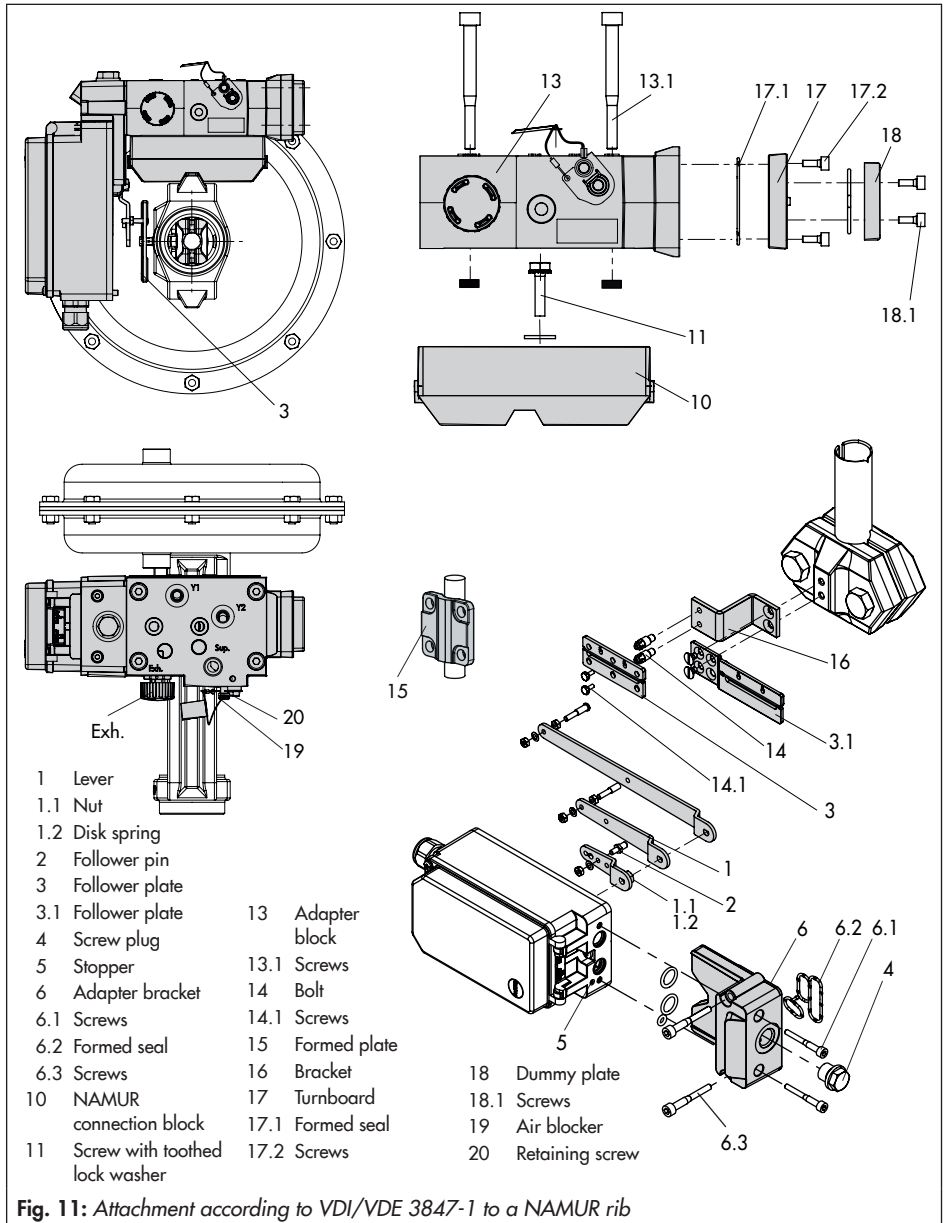

### 5.6 Attachment to Type 3510 Micro-flow Valve

→ Refer to Fig. 12

→ Required mounting parts and accessories: Table 4 on page 16.

→ Observe travel tables on page 17.

The positioner is attached to the valve yoke using a bracket.

1. Fasten the bracket (9.1) to the stem connector.
2. Screw the two bolts (9.2) to the bracket (9.1) of the stem connector (9), place the follower plate (3) on top and use the screws (9.3) for fastening.
3. Mount the travel indication scale (accessories) to the outer side of the yoke using the hex screws (12.1), ensuring that the scale is aligned with the stem connector.
4. Fasten the hex bar (11) onto the outer side of yoke by screwing the M8 screws (11.1) directly into the holes on the yoke.
5. Fasten the bracket (10) to the hex bar (11) using the hex screw (10.1), washer and tooth lock washer.
6. Mount connecting plate (6) or pressure gauge bracket (7) with pressure gauges on the positioner, making sure the two seals are seated properly.
7. Unscrew the standard M lever (1) including follower pin (2) from the positioner shaft.
8. Take the S lever (1) and screw the follower pin (2) in the hole for pin position 17.
9. Place the S lever on the positioner shaft and screw tight using the disk spring (1.2) and nut (1.1).  
Move lever once all the way as far as it will go in both directions.
10. Place positioner on the bracket (10) in such a manner that the follower pin slides into the groove of the follower pin (3). Adjust the lever (1) correspondingly. Screw the positioner to the bracket (10) using both its screws.

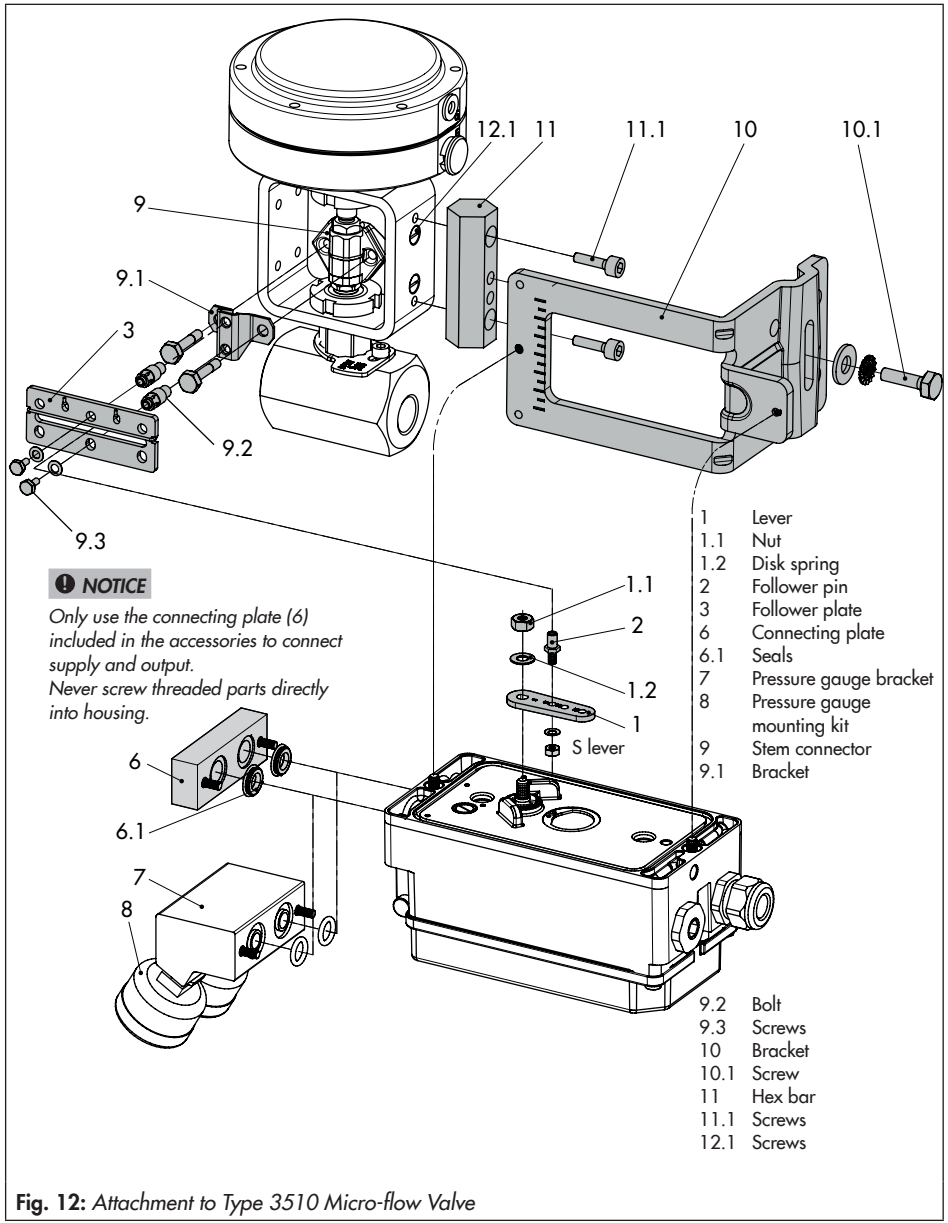

Fig. 12: Attachment to Type 3510 Micro-flow Valve

### 5.7 Reversing amplifier for double-acting actuators

For the use with double-acting actuators, the positioner must be fitted with a reversing amplifier:

- SAMSON Type 3710 Reversing Amplifier, ► EB 8392
- If a different reversing amplifier (item no. 1079-1118 or 1079-1119) is used, mount it as described in section 5.7.1.

#### The following applies to all reversing amplifiers:

The signal pressure of the positioner is supplied at the output 1 of the reversing amplifier. An opposing pressure, which equals the required supply pressure (Z) when added to the pressure at output 1, is applied at output 2.

The following relationship applies:

**output 1 + output 2 = Supply pressure (Z).**

Connect output 1 to the signal pressure connection on the actuator that causes the valve to open when the pressure rises.

Connect output 2 to the signal pressure connection on the actuator that causes the valve to close when the pressure rises.

---

#### **i** Note

How the outputs are marked depends on the reversing amplifier used:

– **Type 3710:** Output 1/2 =  $Y_1/Y_2$

– **1079-1118 and 1079-1119:**

Output 1/2 =  $A_1/A_2$

---

### 5.7.1 Reversing amplifier (1079-1118 or 1079-1119)

→ Refer to Fig. 13.

1. Mount the connecting plate (6) from the accessories to the positioner. Make sure that both O-rings (6.1) are seated correctly.
2. Thread the special nuts (1.3) from the accessories of the reversing amplifier into the boreholes of the connecting plate.
3. Insert the gasket (1.2) into the recess of the reversing amplifier and slide both the hollowed special screws (1.1) into the connecting boreholes **A<sub>1</sub>** and **Z**.
4. Place the reversing amplifier onto the connecting plate (6) and screw tight using both the special screws (1.1).
5. Use a screwdriver (8 mm wide) to screw the enclosed filters (1.6) into the connection boreholes **A<sub>1</sub>** and **Z**.

---

#### **!** NOTICE

*Air can escape uncontrolled from the signal pressure connection.*

*Do not unscrew the sealing plug (1.5) out of the reversing amplifier.*

---

#### **i** Note

*The rubber seal (1.4) is not required and can be removed when the sealing plug is used.*

---

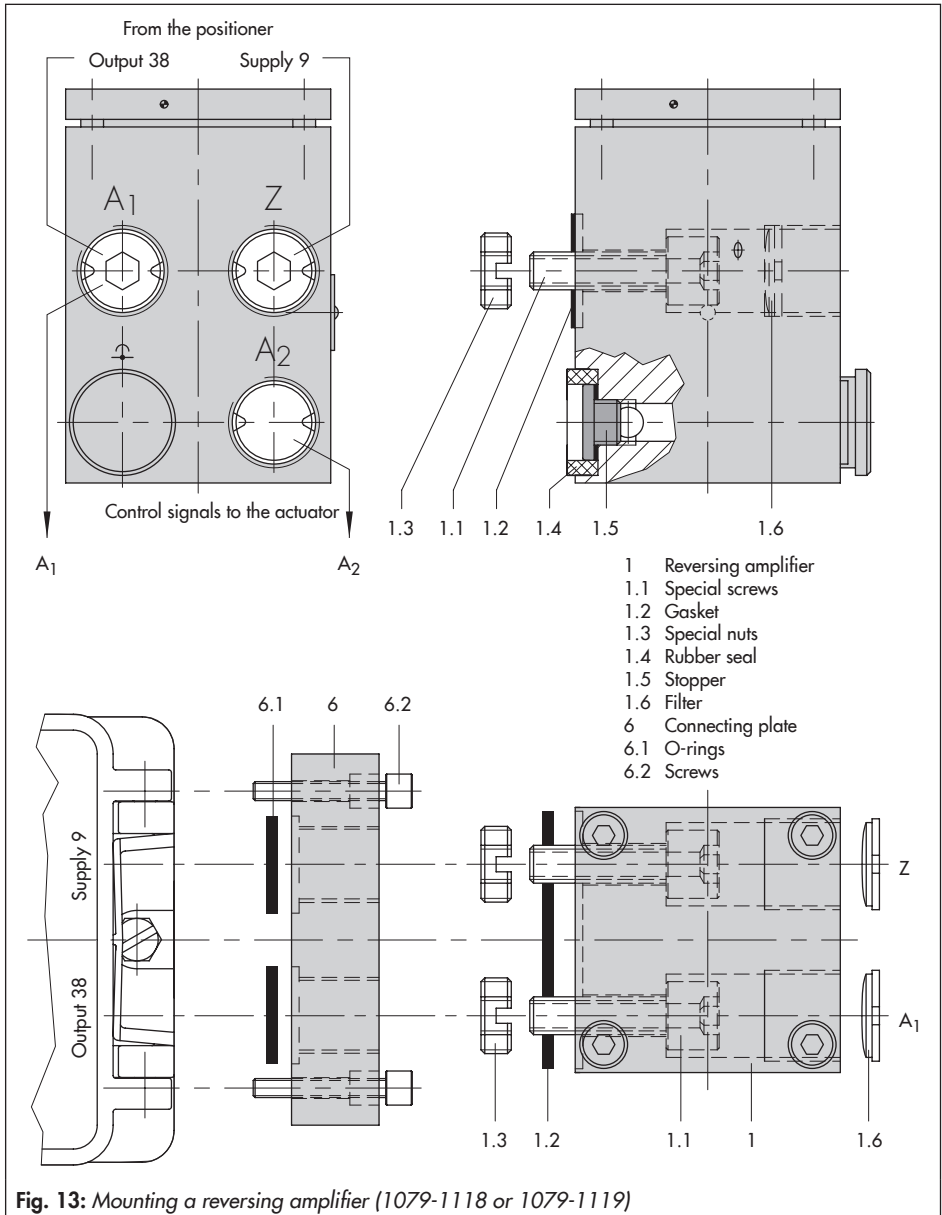

Fig. 13: Mounting a reversing amplifier (1079-1118 or 1079-1119)

## Mounting and start-up

### Pressure gauge attachment

The mounting sequence shown in Fig. 13 remains unchanged. Screw a pressure gauge bracket onto the connections **A<sub>1</sub>** and **Z**.

Pressure gauge	G ¼	1400-7106
bracket	¼ NPT	1400-7107

Pressure gauges for supply air Z and output **A<sub>1</sub>** as listed in Table 2 to Table 4.

## 5.8 Attaching positioners with stainless steel housings

Positioners with stainless steel housings require mounting parts that are completely made of stainless steel or free of aluminum.

---

### **i** Note

*The pneumatic connecting plate and pressure gauge bracket are available in stainless steel (order numbers listed below). The Type 3710 Pneumatic Reversing Amplifier is also available in stainless steel.*

---

Connecting plate	G ¼	1400-7476
(stainless steel)	¼ NPT	1400-7477

Pressure gauge	G ¼	1402-0265
bracket (stainless steel)	¼ NPT	1400-7108

Table 1 to Table 5 apply for attaching positioners with stainless steel housings with the following restrictions:

### Direct attachment

All mounting kits from Table 2 and Table 3 can be used. The connection block is not required. The stainless steel version of the

pneumatic connecting plate routes the air internally to the actuator.

### Attachment according to IEC 60534-6 (NAMUR rib or attachment to rod-type yokes)

All mounting kits from Table 4 can be used. Connecting plate in stainless steel.

## 5.9 Air purging function for single-acting actuators

The instrument air leaving the positioner is diverted to the actuator spring chamber to provide corrosion protection inside the actuator. Observe the following:

### Direct attachment to Type 3277-5 (stem extends FA/stem retracts FE)

The air purging function is automatically provided.

### Direct attachment to Type 3277, 175 to 750 cm<sup>2</sup>

**FA:** Remove the stopper (12.2, Fig. 7) at the connection block and make a pneumatic connection to the spring chamber on the vented side.

---

### **!** NOTICE

*Mounting possibly incorrect when old powder-paint-coated aluminum connection blocks are used.*

*Mount old powder-paint-coated aluminum connection blocks as described in Attachment according to IEC 60534-6 (NAMUR rib or attachment to rod-type yokes).*

---



**FE:** The air purging function is automatically provided.

**Attachment according to IEC 60534-6 (NAMUR rib or attachment to rod-type yokes)**

The positioner requires an additional port for the exhaust air that can be connected over piping. An adapter available as an accessory is used for this purpose:

Threaded bushing	G ¼	0310-2619
(M20x1.5)	¼ NPT	0310-2550

**i Note**

*The adapter uses one of the M20x1.5 connections in the housing which means **only one** cable gland can be installed.*

Should other valve accessories be used which vent the actuator (e.g. solenoid valve, volume booster, quick exhaust valve), this exhaust air must also be included in the purging function. The connection over the adapter at the positioner must be protected with a check valve (e.g. check valve G ¼, order no. 8502-0597) mounted in the piping. Otherwise the pressure in the positioner housing would rise above the ambient pressure and damage the positioner when the exhausting components respond suddenly.

## 5.10 Setting start-up parameters

After the positioner has been mounted on the valve, all switches **S1** to **S10** must be set to **OFF** (see Operating controls of Type 3730-0 Positioner on page 53).

### 5.10.1 Fail-safe position

The switch position of switch S1 depends on the fail-safe position of the valve:

- **AIR TO OPEN** · Upon air supply failure, the valve is completely closed by the actuator. As the signal pressure increases at the positioner output (38), the valve opens.
- **AIR TO CLOSE** · Upon air supply failure, the valve is completely opened by the actuator. As the signal pressure increases at the positioner output, the valve closes.

To determine the switch position, read the associated switch position **S1 = ON** or **OFF** from the cover plate at the actuator symbols.

**The symbols are read properly when the symbol shows the actuator on top of the valve; symbols upside down do not apply.**

**AIR TO OPEN:** Pneumatic connections point to the right **S1 = ON**. Pneumatic connections point to the left **S1 = OFF**.

**AIR TO CLOSE:** Pneumatic connections point to the right **S1 = OFF**. Pneumatic connections point to the left **S1 = ON**.

**AIR TO OPEN** always applies for double-acting actuators. Proceed as described in section 5.11 to connect the reversing amplifier.

## 5.10.2 Volume restriction Q

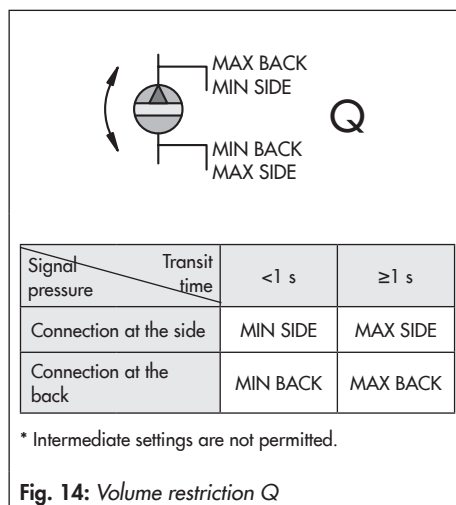

The volume restriction Q serves to adapt the air output capacity to the size of the actuator:

- Actuators with a **transit time < 1 s**, e.g. linear actuators with an effective area smaller than 240 cm<sup>2</sup>, require a restricted air flow rate (MIN).
- Actuators with a **transit time ≥ 1 s** do not require the air flow rate to be restricted (MAX).

The position of volume restriction Q also depends on how the signal pressure is routed at the actuator in **SAMSON actuators**:

### 'SIDE' inscription

- For actuators with a signal pressure connection at the side, e.g. Type 3271-5
- For actuators from other manufacturers

### 'BACK' inscription

- For actuators with a signal pressure connection at the back, e.g. Type 3277-5

## 5.10.3 Travel selection

At switches **S2** and **S3**, select the travel that comes closest to the rated valve travel, taking into account the pin position. If necessary, perform a final adaptation as described in section 7.4.

Pin position	Travel when SPAN adjuster is set to 0							
	S2 OFF	S3 OFF	S2 ON	S3 OFF	S2 OFF	S3 ON	S2 ON	S3 ON
17			5.3		7.5			10.6
25	5.3		7.5		10.6			15
35	7.5		10.6		15			21.2
50	10.6		15		21.2			30
70	15		21.2		30			42.4
100	21.2		30		42.4			60
200	42.4		60		84.8			120

## 5.10.4 Direction of action

At switch **S4**, set the direction of action w/x.

- >> The valve travel x increases as the set point w increases.
- >> The valve travel x decreases as the set point w increases.

Fail-safe action AIR TO OPEN	>>	S4	ON
	<<		OFF
Fail-safe action AIR TO CLOSE	>>	S4	OFF
	<<		ON

### 5.10.5 Signal pressure limitation

Set switch **S5** to **ON** to limit the output signal pressure to 2.4 bar if required by the actuator.

### 5.10.6 Set point

Set switches **S7** and **S8** to determine the input signal, i.e. the range of the set point.

Switch	S7	S8	S7	S8	S7	S8
	OFF	OFF	ON	OFF	OFF	ON
Input mA	4 to 11.9		12.1 to 20		4 to 20	

In split-range operation (Fig. 15, below), the control valves work with smaller set point ranges. The controller output signal is used to control two control valves, dividing it such that the valves move through their entire travel range at half the input signal range each (e.g. first valve set to 4 to 11.9 mA, second valve set to 12.1 to 20 mA). To avoid overlapping, a dead band of  $\pm 0.1$  mA must be taken into account.

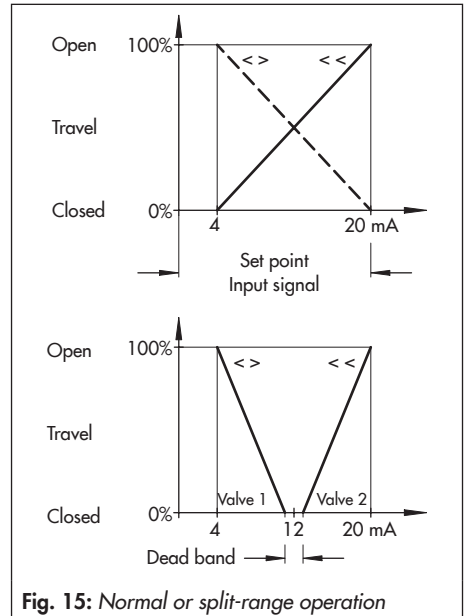

Fig. 15: Normal or split-range operation

**Once all start-up parameters are set:**

- ➔ Connect the supply air. See section 5.11.
- ➔ Connect the electrical power. See section 5.12.

### 5.11 Pneumatic connections

#### **⚠ WARNING**

*Risk of injury by possible movement of exposed parts (positioner, actuator or valve) after connecting the signal pressure. Do not touch or block exposed moving parts.*

#### **ⓘ NOTICE**

*Incorrect connection of the supply air will damage the positioner and will lead to malfunction.*

*Screw the screw fittings into the connecting plate, pressure gauge mounting block or connection block from the accessories.*

The pneumatic ports are located on the back of the positioner (see Fig. 16).

#### **ⓘ NOTICE**

*Risk of malfunction due to failure to comply with required air quality.*

*Only use supply air that is dry and free of oil and dust.*

*Read the maintenance instructions for upstream pressure reducing stations.*

*Blow through all air pipes and hoses thoroughly before connecting them.*

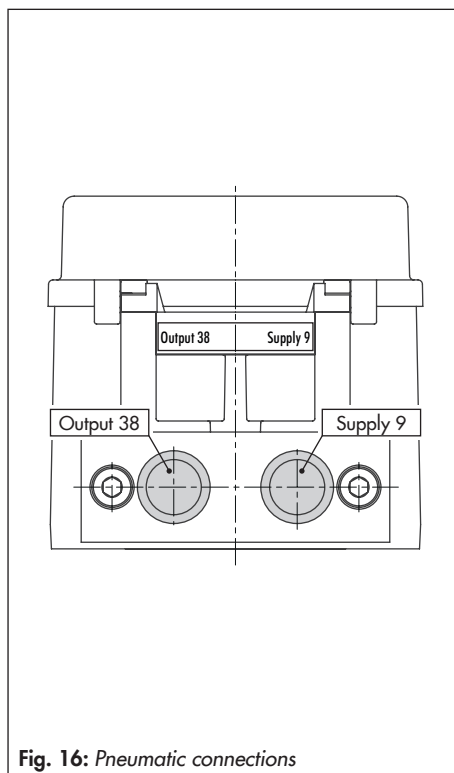

**Fig. 16:** Pneumatic connections

The pneumatic connections in the connecting plate, pressure gauge mounting block and connection block are optionally designed as a bore with  $\frac{1}{4}$  NPT or G  $\frac{1}{4}$  thread. Customary fittings for metal or copper tubing or plastic hoses can be used.

### 5.11.1 Signal pressure connection

The signal pressure connection depends on how the positioner is mounted onto the actuator:

#### Type 3277 Actuator

→ The signal pressure connection is fixed.

#### Attachment according to IEC 60534-6 (NAMUR)

- For "actuator stem retracts" fail-safe action: connect the signal pressure to the connection on top of the actuator.
- For "actuator stem extends" fail-safe action: connect the signal pressure to the connection on the bottom of the actuator.

### 5.11.2 Signal pressure gauges



*To monitor the supply air and signal pressure, we recommend mounting pressure gauges.*

#### Mounting the pressure gauges:

→ See section 5.4 and section Fig. 8

### 5.11.3 Supply pressure

The required supply air pressure depends on the bench range and the actuator's direction of action (fail-safe action).

The bench range is written on the nameplate either as the bench range or signal pressure range depending on the actuator. The direc-

tion of action is marked FA or FE or by a symbol.

#### Actuator stem extends FA (AIR TO OPEN)

Fail-close (for globe and angle valves):

→ Required supply pressure = Upper bench range value + 0.2 bar, at least 1.4 bar.

#### Actuator stem retracts FE (AIR TO CLOSE)

Fail-open (for globe and angle valves):

For tight-closing valves, the maximum signal pressure  $p_{st_{max}}$  is roughly estimated as follows:

$$p_{st_{max}} = F + \frac{d^2 \cdot \pi \cdot \Delta p}{4 \cdot A} \text{ [bar]}$$

d = Seat diameter [cm]

$\Delta p$  = Differential pressure across the valve [bar]

A = Actuator area [cm<sup>2</sup>]

F = Upper bench range value of the actuator [bar]

**If there are no specifications, calculate as follows:**

→ Required supply pressure = Upper bench range value + 1 bar

### 5.11.4 Signal pressure (output)

The signal pressure at the output (38) of the positioner can be restricted to approx. 2.4 bar at the DIP switch **S5**.

### 5.12 Electrical connections

For electrical installation, observe the relevant electrotechnical regulations and the accident prevention regulations that apply in the country of use. In Germany, these are the VDE regulations and the accident prevention regulations of the employers' liability insurance.

---

#### DANGER

##### ***Risk of fatal injury due to the formation of an explosive atmosphere.***

*The following regulations apply to installation in hazardous areas: EN 60079-14 (VDE 0165, Part 1) Explosive Atmospheres – Electrical Installations Design, Selection and Erection.*

---

#### WARNING

*Incorrect electrical connection will render the explosion protection unsafe.*

- Adhere to the terminal assignment.*
  - Do not undo the enameled screws in or on the housing.*
  - Do not exceed the maximum permissible values specified in the EC type examination certificates when interconnecting intrinsically safe electrical equipment ( $U_i$  or  $U_o$ ,  $I_i$  or  $I_o$ ,  $P_i$  or  $P_o$ ,  $C_i$  or  $C_o$  and  $L_i$  or  $L_o$ ).*
- 

The ambient temperature ranges of the tables in the EC type examination certificate apply for the assignment between the permissible ambient temperature, temperature class, maximum short-circuit currents and maximum power  $P_i$  and  $P_o$ .

The following applies additionally: For positioners in type of protection Ex tb (Type 3730-05) and type of protection Ex nA (Type 3730-08), the cable glands and blanking plugs must be certified according to EN 60079-7 (Ex e).

#### **Selecting cables and wires**

Observe **Clause 12 of EN 60079-14** for installation of the intrinsically safe circuits.

Clause 12.2.2.7 applies when running multi-core cables or wires with more than one intrinsically safe circuit.

The radial thickness of the insulation of a conductor for common insulating materials (e.g. polyethylene) must not be smaller than 0.2 mm. The diameter of an individual wire in a fine-stranded conductor must not be smaller than 0.1 mm. Protect the conductor ends against splicing, e.g. by using wire-end ferrules.

When two separate cables or wires are used for connection, an additional cable gland can be installed. Seal cable entries left unused with plugs. Fit equipment used in ambient temperatures **below  $-20\text{ °C}$**  with metal cable entries.

### Equipment for use in zone 2/zone 22

In equipment operated according to type of protection Ex nA (non-sparking equipment) according to EN 60079-15, circuits may be connected, interrupted or switched while energized only during installation, maintenance or repair.

The special conditions of use mentioned in the statement of conformity are to be observed for the rated values and the installation of the series-connected fuse for interconnection of Ex nA circuits.

For Ex nA equipment (non-sparking equipment), circuits may be connected, interrupted or switched while energized only during installation, maintenance or repair.

- Positioners with type of protection Ex nA or Ex tc can be used with a closed cover (no window) or with a cover with window.
- The Types 3730-01, 3730-05 and 3730-08 Positioners are 100 % identical in design, except for the marking and the housing cover.
- For type of protection Ex nA, the VCC connection in the interface adapter must be connected in series with a fuse according to IEC 60127, 250 V F or T with a fuse rating of  $I_N \leq 40$  mA.
- The signal current circuit must be connected in series with a fuse according to IEC 60127-2/VI, 250 V T with a fuse rating of  $I_N \leq 63$  mA.
- The transmitter current circuit must be connected in series with a fuse according to IEC 60127-2/VI, 250 V T with a fuse rating of  $I_N \leq 40$  mA.

The fuses must be installed outside the hazardous area.

### Cable entry

Cable entry with M20x1.5 cable gland, 6 to 12 mm clamping range.

There is a second M20x1.5 threaded hole in the housing that can be used for additional connection, when required. The screw terminals are designed for wire cross-sections of 0.2 to 2.5 mm<sup>2</sup>. Tighten the screws by 0.5 to 0.6 Nm.

The wires for the set point must be connected to the terminals 11 and 12 located in the housing. Only use a **current source**.

---

#### NOTICE

*An incorrect electrical power supply will damage the positioner.*

*Do not connect the positioner to a voltage source.*

- 
- ➔ Observe the relevant regulations for installation in hazardous areas.

---

#### NOTICE

*Risk of positioner malfunction.*

*The set point must not fall below 3.6 mA while the positioner is running.*

---

## Mounting and start-up

### Accessories

Cable glands M20x1.5	Order no.
Black plastic (6 to 12 mm clamping range)	8808-1011
Blue plastic (6 to 12 mm clamping range)	8808-1012
Nickel-plated brass (6 to 12 mm clamping range)	1890-4875
Nickel-plated brass (10 to 14 mm clamping range)	1922-8395
Stainless steel 1.4305 (8 to 14.5 mm clamping range)	8808-0160

### Adapter M20x1.5 to ½ NPT

Powder-coated aluminum	0310-2149
Stainless steel	1400-7114

→ Connect the electrical power (mA signal)  
as shown in Fig. 17.

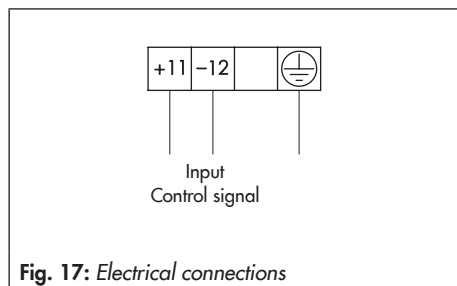

Fig. 17: Electrical connections



## 6 Operation

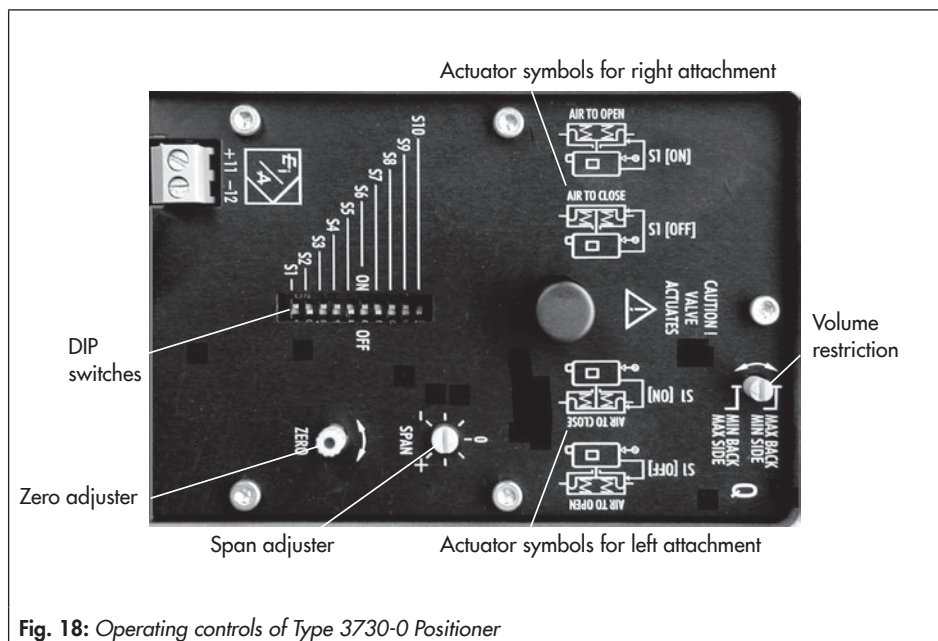

Fig. 18: Operating controls of Type 3730-0 Positioner

### DIP switches S1 to S10

The positioner is mainly operated via the DIP switches, which allow you to set the most important functions.

DIP switches and their functions	
S1	Actuator fail-safe action
S2/S3	Rated travel of the control valve
S4	Direction of action w/x
S5	Limit output signal pressure to 2.4 bar
S6	Change gain factor
S7/S8	Set range of set point
S9/S10	Activate tight-closing function

### ZERO and SPAN adjusters

The ZERO and SPAN potentiometers are used to adjust the starting point (zero) and the upper range value (span) of the set point.

### Volume restriction Q

The volume restriction serves to adapt the air output capacity to the size of the actuator. Depending on the air passage at the actuator, two fixed settings are available.

## 7 Operating the positioner

### 7.1 Setting zero

#### NOTICE

Before setting zero, settings using switches S1 to S5 as well as switches S7 and S8 must be made first (see section 5.10).

- Set SPAN adjuster to 0.
- Adjust the input signal according to the table below using an ammeter.
- Turn ZERO adjuster until the plug stem just starts to move from its initial position.

Direction of action	Set point [mA]	Input signal for zero [mA]
>>	4 to 20	4
>>	4 to 12	4
>>	12 to 20	12
<>	4 to 20	20
<>	4 to 12	12
<>	12 to 20	20

### 7.2 Reducing gain

- Move the valve in small steps. If the valve tends to hunt, set switch S6 to ON to reduce the gain of the control loop.

### 7.3 Adapting the travel

In case the rated travel of the control valve does not correspond with the selected travel according to the table in section 5.10.3:

- Adjust the upper range value of the input signal (e.g. 4, 12 or 20 mA) using the ammeter.
- Turn the SPAN adjuster until the plug stem moves as far as it will go to the end position.

### 7.4 Activate tight-closing function

Having adjusted zero and span, the tight-closing function (description on page 13) must be activated at switches S9 and S10 to ensure a tight valve shut-off.

AIR TO OPEN	S9: ON	S10: OFF
AIR TO CLOSE	S9: OFF	S10: ON
Three-way valve	S9: ON	S10: ON
Tight-closing function deactivated	S9: OFF	S10: OFF

## 8 Servicing

### **i Note**

The positioner was checked by SAMSON before it left the factory.

- The product warranty becomes void if service or repair work not described in these instructions is performed without prior agreement by SAMSON's After-sales Service department.
- Only use original spare parts by SAMSON, which comply with the original specifications.

The positioner does not require any maintenance.

### Filters

There are filters with a 100 µm mesh size in the pneumatic connections for supply and output which can be removed and cleaned, if required.

### Supply air pressure reducing stations

The maintenance instructions of any upstream supply air pressure reducing stations must be observed.

## 8.1 Preparation for return shipment

Defective positioners can be returned to SAMSON for repair.

Proceed as follows to return devices to SAMSON:

1. Put the control valve out of operation.  
See associated valve documentation.

2. Remove the positioner (see section 10).
3. Send the positioner to your nearest SAMSON subsidiary. SAMSON subsidiaries are listed on our website at  
▶ [www.samson.de](http://www.samson.de) > Contact.

## 9 Malfunctions

→ Troubleshooting (see Table 10)

**Table 10:** Troubleshooting

Description of fault	Measures
Actuator moves too slowly.	<ul style="list-style-type: none"> <li>→ Check the supply pressure.</li> <li>→ Check the cross-section of the piping and screw fittings.</li> <li>→ Check the configuration of the mounting parts.</li> </ul>
Actuator moves in the wrong direction.	<ul style="list-style-type: none"> <li>→ Check piping.</li> <li>→ Check the configuration of the mounting parts.</li> </ul>
Air leaks from the positioner.	<ul style="list-style-type: none"> <li>→ Check the seals in the connecting plate.</li> </ul>

### **i Note**

Contact SAMSON's After-sales Service department for malfunctions not listed in the table.

## Decommissioning and removal

### 9.1 Emergency action

Upon failure of the air supply or electric signal, the positioner vents the actuator, causing the valve to move to the fail-safe position determined by the actuator.



#### Tip

*Emergency action in the event of valve or actuator failure is described in the associated valve and actuator documentation.*

→ The plant operator is responsible for emergency action to be taken in the plant.

### 10 Decommissioning and removal



#### DANGER

**Risk of fatal injury due to ineffective explosion protection.**

*The explosion protection becomes ineffective when the positioner cover is opened.*

*The following regulations apply to installation in hazardous areas: EN 60079-14 (VDE 0165, Part 1).*



#### NOTICE

*The process is disturbed by interrupting closed-loop control.*

*Do not mount or service the positioner while the process is running and only after isolating the plant by closing the shut-off valves.*

### 10.1 Decommissioning

To decommission the positioner before removing it, proceed as follows:

1. Disconnect and lock the air supply and signal pressure.
2. Open the positioner cover and disconnect the wires for the control signal.

### 10.2 Removing the positioner

1. Disconnect the wires for the control signal from the positioner.
2. Disconnect the lines for supply air and signal pressure (not required for direct attachment using a connection block).
3. To remove the positioner, loosen the three fastening screws on the positioner.

### 10.3 Disposal



SAMSON is a producer registered at the following European institution ► <https://www.eurm.org/national-registers/national-registers>.  
WEEE reg. no.:  
DE 62194439/FR 025665

- Observe local, national and international refuse regulations.
- Do not dispose of components, lubricants and hazardous substances together with your other household waste.

**i Note**

We can provide you with a recycling passport according to PAS 1049 on request. Simply e-mail us at [aftersalesservice@samsongroup.com](mailto:aftersalesservice@samsongroup.com) giving details of your company address.

**💡 Tip**

On request, we can appoint a service provider to dismantle and recycle the product.

## 11 Appendix

### 11.1 After-sales service

Contact SAMSON's After-sales Service department for support concerning service or repair work or when malfunctions or defects arise.

#### E-mail address

You can reach the After-sales Service Department at [aftersalesservice@samson](mailto:aftersalesservice@samson).

#### Addresses of SAMSON AG and its subsidiaries

The addresses of SAMSON AG, its subsidiaries, representatives and service facilities worldwide can be found on our website ([www.samson.de](http://www.samson.de)) or in all SAMSON product catalogs.

### Required specifications

Please submit the following details:

- Order number and position number in the order
- Type, serial number, firmware version, device version

### 11.2 Certificates

The certificates valid at the time when these instructions were published are included on the next pages.

The latest certificates are available on the Internet at ► [www.samson.de](http://www.samson.de) > Product selector > Valve accessories > Type 3730-0 > Downloads > Certificates

## TRANSLATION

Your ref. Offenbach, 2005-11-21  
 P. Opl. Contact  
 2005-11-08 Tel. (+49) 69 8396-249  
 1140534 Fax (+69) 8396-716  
 63303hh-wah E-mail: gerhard.behl@vde.com

## Test report for Information of the Applicant

## Testing of the Degree of Protection on enclosures of Type 370 and Type 371 Positioners

This test report contains the result of a single investigation carried out on the product submitted. A sample of this product was tested to find the accordance with the thereafter listed standards resp. parts of standards.

The test report does not entitle to use a VDE Certification mark and the "GS = *geprüfte Sicherheit (act safe?)*" and does not refer to all VDE specifications applicable to the tested product.

This report may only be passed to a third party in its complete wording including this preamble and the date of issue.

Any publication or reproduction requires the prior written approval of the VDE Testing and Certification Institute.

## 1 Assignment

The samples described in 2 below were tested for compliance with the IP 66 degree of protection.

## 2 Samples

2.1. Type 3730 Positioner

2.2. Type 3731 Positioner

VDE VERBAND DIREKTORIELEKTROTECHNIK  
 ELEKTRONIK INFORMATIONSTECHNIK e.V.  
 Pfaffenbergring 10  
 D-63899 Offenbach  
 E-mail: vde-institut@vde.com

Testing and Certification Institute  
 Merianstrasse 28  
 D-63899 Offenbach

## 3 Basis of assessment

DIN EN 60529:VDE 0470 Part 1:2004-09  
 Degree of protection provided by enclosures (IP Code)  
 German version EN 60529:1999/VA.12:000

## 4 Execution of the tests

The dust test had already been carried out on the Type 3730 Positioner under the reference number: 479000-9010-0001/32752 and on the Type 3731 Positioner under the reference number: 479000-9010-0001/58945 with suction as per category 1 at the connecting enclosures of the positioners and solenoid valves. The under pressure was 2 kPa and the test lasted 8 hours.

## 5 Test results

The testing of the samples described in 2 above yielded the following results:

Protecting against access to hazardous parts and against ingress of solid foreign objects according to DIN EN 60529:VDE 0470 Part 1:2004-09

IP6X satisfied

Preventing accidental ingress of water according to DIN EN 60529:VDE 0470 Part 1:2004-09

IPX6 satisfied

The positioner enclosures in the versions submitted meet the requirements of IP 66 degree of protection.

There was no ingress of either dust or water.

VDE Prüf und Zertifizierungsinstitut  
 Pfaffenbergring 10/33

(Signature)

(Signature)

Gerhard Behl

VDE VERBAND DIREKTORIELEKTROTECHNIK  
 ELEKTRONIK INFORMATIONSTECHNIK e.V.  
 Pfaffenbergring 10  
 D-63899 Offenbach  
 E-mail: vde-institut@vde.com

Testing and Certification Institute  
 Merianstrasse 28  
 D-63899 Offenbach

[Federal logo]

TRANSLATION

(1) **EC TYPE EXAMINATION CERTIFICATION**

(2) Equipment and Protective Systems Intended for Use in Potentially Explosive Atmospheres –  
**Directive 94/9/EC**

(3) EC Type Examination Certificate Number

**PTB 03 ATEX 2099**



(4) Equipment: Model 3730-01 . . . Positioner  
(5) Manufacturer: SAMSON AG Mess- und Regeltechnik  
(6) Address: Weismüllerstr. 3, 60314 Frankfurt, Germany

(7) This equipment and any acceptable variation thereof are specified in the schedule to this certificate.

(8) The Physikalisch-Technische Bundesanstalt, notified body number 0102 in according to Article 9 of the Council Directive 94/9/EC of 23 March 1994, certifies that this equipment has been found to comply with the Essential Health and Safety Requirement relating to the design and construction of equipment and protective systems intended for use in potentially explosive atmospheres given in Annex II to the Directive.

The examination and test results are recorded in confidential report: **PTB Ex 03-23199**

(9) The essential health and safety requirements are satisfied by compliance with

**EN 50014: 1997+A1+A2 EN 50020: 2002**

(10) If the sign "X" is placed after the certificate number, it indicates that the equipment is subject to special conditions for safe use specified in the schedule to this certificate.

(11) This EC Type Examination Certificate relates only to the design and examination of the specified equipment in compliance with Directive 94/9/EC. Further requirements of this Directive apply to the manufacture and supply of the equipment. These requirements are not covered by this Certificate.

Page 1/4

---

EC Type Examination Certificates without signature and seal are invalid.  
This EC Type Examination Certificate may only be reproduced in its entirety and without any changes, schedule included.  
Extracts or changes shall require the prior approval of the Physikalisch-Technische Bundesanstalt.

Physikalisch-Technische Bundesanstalt., Bundesallee 100, D-38116 Braunschweig

Ptb37-3730-01.doc

- (12) The marking of the equipment shall include the following:



Zertifizierungsstelle Explosionsschutz  
By order

Braunschweig, 21 July 2003

(Signature)

(Seal)

Dr. Ing. U. Gerlach  
Regierungsdirektor

Page 2/4

---

EC Type Examination Certificates without signature and seal are invalid.  
This EC Type Examination Certificate may only be reproduced in its entirety and without any changes, schedule included.  
Extracts or changes shall require the prior approval of the Physikalisch-Technische Bundesanstalt.

Physikalisch-Technische Bundesanstalt, Bundesallee 100, D-38116 Braunschweig

Ptb37-3730-01.doc



## Schedule

(13)

(14) EC TYPE EXAMINATION CERTIFICATE No. PTB 03 ATEX 2099

(15) Description of Equipment

The Model 3730-01 . . Positioner is a single- or double-acting positioner for attachment, to linear or rotary actuators. It serves for translating control signals into valve stem positions.

The Model 3730-01 . . Positioner is a passive two-terminal network which may be connected to any certified intrinsically safe circuit, provided the permissible maximum values of  $U_i$ ,  $I_i$  and  $P_i$  are not exceeded.

For air supply non-combustible media are used.

The device is intended for use inside and outside of hazardous locations.

The correlation between temperature classification and permissible temperature ranges is shown in the table below.

Temperature class	Permissible ambient temperature range
T6	-40°C . . . 50°C
T5	-40°C . . . 70°C
T4	-40°C . . . 80°C

Electrical data

Signal circuit  
(terminals 11/12)

Type of protection: Intrinsic safe EEx ia IIC  
only for connection to a certified intrinsically safe circuit

Maximum values:

$U_i = 28 \text{ V}$   
 $I_i = 115 \text{ mA}$   
 $P_i = 1 \text{ W}$

$C_i = 5,3 \text{ nF}$ ;  $L_i$  negligible

(16) Test Report PTB Ex 03-23199

Page 3/4

---

EC Type Examination Certificates without signature and seal are invalid.  
This EC Type Examination Certificate may only be reproduced in its entirety and without any changes, schedule included.  
Extracts or changes shall require the prior approval of the Physikalisch-Technische Bundesanstalt.

Physikalisch-Technische Bundesanstalt., Bundesallee 100, D-38116 Braunschweig

Ptb37-3730-01.doc

Schedule to the EC Type Examination Certificate No. PTB 03 ATEX 2099

(17) Special conditions for safe use

None

(18) Special health and safety requirements

In compliance with the standards specified above.

Zertifizierungsstelle Explosionsschutz  
By order

Braunschweig, 21 July 2003

(Signature) (seal)

Dr. Ing. U. Gerlach  
Regierungsdirektor

Page 4/4

---

EC Type Examination Certificates without signature and seal are invalid.  
This EC Type Examination Certificate may only be reproduced in its entirety and without any changes, schedule included.  
Extracts or changes shall require the prior approval of the Physikalisch-Technische Bundesanstalt.

Physikalisch-Technische Bundesanstalt, Bundesallee 100, D-38116 Braunschweig

Ptb37-3730-01.doc

TRANSLATION

ADDENDUM No. 1

in compliance with Directive 94/9/EC Annex III Clause 6  
to the EC Type Examination Certificate PTB 03 ATEX 2099

**Equipment:** Model 3730-01

**Marking:**  II 2G EEx ia IIC T6

**Manufacturer:** SAMSON AG Mess- und Regeltechnik

**Address:** Weismüllerstr. 3, D-60314 Frankfurt, Germany

**Description of the additions and modifications**

The Model 3730-01 . . satisfy the requirements of EN 50281-1-1: 1998 relating to electrical apparatus with protection provided by the enclosure.

The Positioners shall be provided in addition with the following marking:

 II 2D IP 65 T80 °C bzw. II 2D IP 65 T80 °C

all the other data apply without change also to this Addendum No. 1.

Test report: PTB Ex 06-26110

Zertifizierungsstelle Explosionsschutz  
By order

Braunschweig, 25 August 2006

(Signature) (Seal)

Dr. Ing. U. Johannsmeyer  
Regierungsdirektor

EC Type examination Certificates without signature and seal are invalid.  
This EC Type Examination Certificate may only be reproduced in its entirety and without any change, schedule included. Extracts or changes shall require the prior approval of the Physikalisch-Technische Bundesanstalt.

## 2. SUPPLEMENT

according to Directive 94/9/EC Annex III.6

to EC-TYPE-EXAMINATION CERTIFICATE PTB 03 ATEX 2099

(Translation)

Equipment: Positioner, type 3730-01..

Marking:  II 2 G EEx ia IIC T6 and  
II 2 D IP65 T 80 °C or II 2 D IP66 T 80 °C

Manufacturer: SAMSON AG Mess- und Regeltechnik

Address: Weismüllerstr. 3, 60314 Frankfurt, Germany

### Description of supplements and modifications

In the future the positioner, type 3730-01.. may also be manufactured according to the test documents listed in the test report.

The state of the standards is updated. Further modifications have not been made.

The thermal and electrical data are represented in summary.

For relationship between temperature class and the permissible ambient temperature ranges, reference is made to the table:

Temperature class	Permissible ambient temperature range
T6	-40 °C ... 50 °C
T5	-40 °C ... 70 °C
T4	-40 °C ... 80 °C

Sheet 1/2

EC-type-examination Certificates without signature and official stamp shall not be valid. The certificates may be circulated only without alteration. Extracts or alterations are subject to approval by the Physikalisch-Technische Bundesanstalt. In case of dispute, the German text shall prevail.

Physikalisch-Technische Bundesanstalt • Bundesallee 100 • 38116 Braunschweig • GERMANY

Electrical data

Signal circuit .....type of protection Intrinsic Safety Ex ia IIC  
(terminals 11/12) only for connection to a certified intrinsically safe circuit

Maximum values:

$$U_i = 28 \text{ V}$$

$$I_i = 115 \text{ mA}$$

$$P_i = 1 \text{ W}$$

$$C_i = 5,3 \text{ nF}$$

$$L_i \text{ negligibly low}$$

All other specifications given in the EC-type examination certificate apply without changes.

The future marking reads:

 II 2 G Ex ia IIC T6 Gb and II 2 D Ex tb IIIC T80 °C Db IP65/66

Applied standards

EN 60079-0:2009

EN 60079-11:2012

EN 60079-31:2009

Test report: PTB Ex 13-23135

Zertifizierungssektor Explosionsschutz  
On behalf of PTB:

  
Dr.-Ing. U. Johannsmeyer  
Direktor und Professor



Braunschweig, September 17, 2013

Sheet 2/2

EC-type-examination Certificates without signature and official stamp shall not be valid. The certificates may be circulated only without alteration. Extracts or alterations are subject to approval by the Physikalisch-Technische Bundesanstalt. In case of dispute, the German text shall prevail.

Physikalisch-Technische Bundesanstalt • Bundesallee 100 • 38116 Braunschweig • GERMANY

### 3. SUPPLEMENT

according to Directive 94/9/EC Annex III.6

to EC-TYPE-EXAMINATION CERTIFICATE PTB 03 ATEX 2099

(Translation)

Equipment: Positioner type 3730-01.. and 3730-05..

Marking:  II 2 G Ex ia IIC T6 Gb and  
II 2 D Ex tb IIIC T 80°C Db IP65/66

Manufacturer: SAMSON AG Mess- und Regeltechnik

Address: Weismüllerstraße 3, 60314 Frankfurt, Germany

#### Description of supplements and modifications

In the future the Positioner type 3730-01.. and 3730-05.. may also be manufactured and operated according to the test documents listed in clause 3 of the test report.

The modifications concern the update of the applied standards, the adding of another type notation for dust ignition protection by enclosure, the implementation of dust ignition protection by Intrinsic Safety and the application of alternative gasket material of the enclosure.

All further specifications of the EC-Type-Examination certificate as well as the 1<sup>st</sup> and 2<sup>th</sup> supplement apply without changes for this 3<sup>th</sup> supplement.

In the future the marking will read

 II 2 G Ex ia IIC T6...T4 Gb and II 2 D Ex ia IIIC T 80 °C Db resp.  
II 2 D Ex tb IIIC T 80 °C Db

#### Applied standards

EN 60079-0:2012/A11:2013 EN 60079-11:2012 EN 60079-31:2014

Test report: PTB Ex 16-25125

Konformitätsbewertungsstelle, Bektor Explosionsschutz

Braunschweig, April 19, 2016

On behalf of PTB:

  
Dr.-Ing. F. Lfenesch  
Regierungsdirektor



Sheet 1/1

EC-type-examination Certificates without signature and official stamp shall not be valid. The certificates may be circulated only without alteration. Extracts or alterations are subject to approval by the Physikalisch-Technische Bundesanstalt. In case of dispute, the German text shall prevail.

Physikalisch-Technische Bundesanstalt • Bundesallee 100 • 38116 Braunschweig • GERMANY

[Federal logo]

TRANSLATION

**Statement of conformity**

- (1)
- (2) Equipment and Protective Systems Intended for Use in Potentially Explosive Atmospheres –  
**Directive 94/9/EC**
- (3) EC Type Examination Certificate Number
- PTB 03 ATEX 2179 X**
- (4) Equipment: Model 3730-08.. e/p Positioner
- (5) Manufacturer: SAMSON AG Mess- und Regeltechnik
- (6) Address: Weismüllerstr. 3, 60314 Frankfurt am Main, Germany
- (7) The equipment and any acceptable variation thereof are specified in the schedule to this certificate and the documents referred to therein.
- (8) The Physikalisch-Technische Bundesanstalt, notified body number 0102 according to Article 9 of the Council Directive 94/9/ of 23 March 1994, certifies that this equipment has been found to comply with the essential health and safety requirements relating to the design and construction of equipment and protective systems intended for use in potentially explosive atmospheres specified in Annex II to the Directive.
- The examination and test results are recorded in confidential report. **PTB Ex 03-23300**
- (9) The essential health and safety requirements are satisfied by compliance with
- EN 50021: 1999**
- (10) If the sign “X” is placed after the certificate number, it indicates that the equipment is subject to special conditions for safe use as specified in the schedule to this certificate.
- (11) In compliance with the Directive 94/9/EC this Statement of Conformity relates only to the design and construction of the equipment specified. Further requirements of this Directive apply to manufacture and marketing of this equipment.



---

EC Type Examination Certificates without signature and seal are invalid.  
This EC Type Examination Certificate may only be reproduced in its entirety and without any changes, schedule included.  
Extracts or changes shall require the prior approval of the Physikalisch-Technische Bundesanstalt.

Physikalisch-Technische Bundesanstalt., Bundesallee 100, D-38116 Braunschweig

Ptb37Ex n.doc

- (12) The marking of the equipment shall include the following:



Zertifizierungsstelle Explosionsschutz  
By order

Braunschweig, 30. September 2003

(Signature) (Seal)

Dr. Ing. U. Johannsmeyer  
Regierungsdirektor

---

EC Type Examination Certificates without signature and seal are invalid.  
This EC Type Examination Certificate may only be reproduced in its entirety and without any changes, schedule included.  
Extracts or changes shall require the prior approval of the Physikalisch-Technische Bundesanstalt.

Physikalisch-Technische Bundesanstalt, Bundesallee 100, D-38116 Braunschweig

Ptb37Ex n.doc



## Schedule

(13)

(14) EC TYPE EXAMINATION CERTIFICATE No. PTB 03 ATEX 2179 X

(15) **Description of Equipment**

The Model 3730-08.. e/p Positioner is a single- or double-acting positioner for attachment to linear or rotary actuators. It serves for translating control signals into valve stem positioners.

For pneumatic auxiliary power non-combustible media are used.

The device is intended for use inside and outside of hazardous locations.

The correlation between temperature classification and permissible ambient temperature ranges is shown in the table below:

Temperature class	Permissible ambient temperature range
T6	-40 °C ...50 °C
T5	-40 °C ...70 °C
T4	-40 °C ... 80 °C

**Electrical data**

Signal circuit: (terminals 11/12)

Type of protection EEx nA II

(16) Test report **PTB Ex 03-23300**

(17) The signal circuit (terminals 11/12) shall be preceded by a fuse installed outside of the hazardous location. This fuse shall comply with IEC 60127-2/II, 250 V F, or with IEC 50127-2/VI, 250 V T with a maximum fuse nominal current  $I_N \leq 80$  mA.

The cable entries of the enclosure for the Model 3730.08.. e/p Positioner shall provide at least Degree of Protection IP 54 in compliance with EN 60529. The wiring shall be connected in such a manner that the connection facilities are not subjected to pull and twisting.

(18) **Basis health and safety requirements**

Are satisfied by compliance with the standard specified above.

Zertifizierungsstelle Explosionsschutz

Braunschweig, 30. September 2003

By order

(Signature)

(seal)

Dr. Ing. U. Johannsmeyer  
Regierungsdirektor

---

EC Type Examination Certificates without signature and seal are invalid.  
This EC Type Examination Certificate may only be reproduced in its entirety and without any changes, schedule included.  
Extracts or changes shall require the prior approval of the Physikalisch-Technische Bundesanstalt.

Physikalisch-Technische Bundesanstalt, Bundesallee 100, D-38116 Braunschweig

Ptb37Ex n.doc

**ADDENDUM No. 1**  
**to the Statement of conformity PTB 03 ATEX 2179 X**

Equipment: Model 3730-08.. e/p Positioner

Marking:  II 3G EEx nA II T6

Manufacturer: SAMSON AG, Mess- und Regeltechnik

Address: Weismüllerstr. 3, D-60314 Frankfurt, Germany

**Description of the additions and modifications**

The Model 3730-08.. e/p Positioner may be connected in future also to energy-limited circuits with type of protection EEx nL IIC T6. The electrical data are complemented as follows:

**Electrical data**

Signal circuit  
(terminals 11/12)

Type of protection EEx nA II or  
Type of protection EEx nL IIC

Maximum Values:  
 $U_i = 28V$   
 $I_i = 115mA$   
 $P_i = 1 W$   
 $C_i = 5.3nF$   
 $L_i = negligible$  or

$U_i = 30V$   
 $I_i = 100mA$   
 $P_i = 1 W$   
 $C_i = 5.3nF$   
 $L_i = negligible$

The equipment is mounted in a metallic enclosure which ensures at least degree of protection IP 54.

The marking of the Model 3730-08 e/p Positioner is complemented as follows:

 II 3 G EEx nA II T6 or II 3 G EEx nL IIC T6  
II 3 D IP 54 T 80 °C or II 3 D IP 65 T 80 °C

Statements of Conformity without signature and seal are invalid. This Statement of Conformity may be reproduced only without changes. The results laid down in this test report refer exclusively to the test object and the technical documentation submitted. Extracts or changes will require the approval of the Physikalisch-Technische Bundesanstalt.

The special conditions are complemented as follows:

If the signal circuit of the Model 3730-08 e/p Positioner is to be connected to a circuit with type of protection EEx nA II, the signal circuit shall be preceded by a fuse complying with IEC 60127-2/II, 250 V F or IEC 60127/VI, 250 V T with a maximum current rating of  $I_N \leq 80$  mA. The fuse shall be installed outside of the hazardous location.

If the signal circuit is to be connected to a circuit with type of protection EEx nL IIC, no preceding fuse need be provided.

The manufacturer shall ensure and supply documentary evidence that the equipment enclosure including and cable entries provides either degree of protection IP54 or IP65 according to EN 60529, depending on the application.

All the other data apply unaltered also to this Addendum No. 1

Test report: **PTB Ex-04-24290**

Zertifizierungsstelle Explosionsschutz  
By order

Braunschweig, 9. December 2004

(Signature)      (Seal)

Dr. Ing. U. Johannsmeyer  
Regierungsdirektor

---

Statements of Conformity without signature and seal are invalid. This Statement of Conformity may be reproduced only without changes. The results laid down in this test report refer exclusively to the test object and the technical documentation submitted. Extracts or changes will require the approval of the Physikalisch-Technische Bundesanstalt.

**2. SUPPLEMENT**  
**to CONFORMITY STATEMENT PTB 03 ATEX 2179 X**  
**(Translation)**

Equipment: e/p-positioner, type 3730-08..

Marking:  II 3 G EEx nA II T6 or II 3 G EEx nL IIC T6 or  
 II 3 D IP54 T 80 °C or II 3 D IP65 T 80 °C

Manufacturer: SAMSON AG Mess- und Regeltechnik

Address: Weismüllerstr. 3, 60314 Frankfurt, Germany

Description of supplements and modifications

In the future the positioner, type 3730-08.. may also be manufactured according to the test documents listed in the test report.

The state of the standards is updated. Further modifications have not been made.

The thermal and electrical data are represented in summary.

For relationship between temperature class and the permissible ambient temperature ranges, reference is made to the table:

Temperature class	Permissible ambient temperature range
T6	-40 °C ... 50 °C
T5	-40 °C ... 70 °C
T4	-40 °C ... 80 °C

Electrical data

Signal circuit .....type of protection Intrinsic Safety Ex ic IIC or Ex nA II  
 (terminals 11/12) only for connection to a certified intrinsically safe circuit

Operational maximum values:

U<sub>i</sub> = 28 V  
 I<sub>i</sub> = 115 mA  
 P<sub>i</sub> = 1 W

Sheet 1/2

Conformity Statements without signature and official stamp shall not be valid. The certificates may be circulated only without alteration. Extracts or alterations are subject to approval by the Physikalisch-Technische Bundesanstalt. In case of dispute, the German text shall prevail.

Physikalisch-Technische Bundesanstalt • Bundesallee 100 • 38116 Braunschweig • GERMANY

ZSEEx10201e.dadm ZSEEx10201e

$C_1 = 5.3 \text{ nF}$   
 $L_1$  negligibly low

The special conditions are altered.

### Special conditions

#### **Type of protection Ex ic IIC**

A fuse shall be connected in series to the signal circuit if this is connected to a circuit of type of protection Ex ic IIC.

The equipment may be switched operationally.

#### **Type of protection Ex nA II**

If the position indicator circuit is connected to a circuit of type of protection Ex nA II a fuse according to IEC 60127-2/VI, 250 V T with a nominal fuse current of max.  $I_N \leq 40 \text{ mA}$  shall be connected in series. This fuse shall be arranged outside of the hazardous area.

Connection, disconnection and switching of energized circuits is only permitted during installation, maintenance and repair work.

#### **Protection by enclosure**

The manufacturer has to guarantee and document that the enclosure of the equipment including all cable entry fittings complies with a degree of protection of either IP 54 or IP 65 according to IEC 60529 depending on the intended application.

All other specifications given in the conformity statement apply without changes also to this supplement.

The future marking reads:

 II 3 G Ex ic IIC T6 Gc or II 3 G Ex nA II T6 Gc and  
II 3 D Ex tc IIIC T80 °C Dc IP65

#### Applied standards

EN 60079-0:2009

EN 60079-11:2012

EN 60079-31:2009

#### Test report:

PTB Ex 13-23136

Zertifizierungssektor Explosionschutz  
By order:

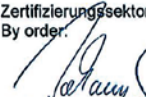
  
Dr.-Ing. U. Johannsmeyer  
Direktor und Professor



Braunschweig, September 17, 2013

Sheet 2/2

Conformity Statements without signature and official stamp shall not be valid. The certificates may be circulated only without alteration. Extracts or alterations are subject to approval by the Physikalisch-Technische Bundesanstalt. In case of dispute, the German text shall prevail.

Physikalisch-Technische Bundesanstalt • Bundesallee 100 • 38116 Braunschweig • GERMANY

# Physikalisch-Technische Bundesanstalt

Braunschweig und Berlin

## 3. SUPPLEMENT

to CONFORMITY STATEMENT PTB 03 ATEX 2179 X

(Translation)

Equipment: e/p-positioner, type 3730-08..

Marking:  II 3 G Ex ic IIC T6 Gc resp. II 3 G Ex nA II T6 Gc and II 3 D Ex tc IIIC T80 °C Dc IP65

Manufacturer: SAMSON AG Mess- und Regeltechnik

Address: Weismüllerstr. 3, 60314 Frankfurt, Germany

### Description of supplements and modifications

In the future the positioner type 3730-08.. may also be manufactured according to the test documents listed in the test report.

The modifications concern the update of the applied standards, the discontinue of the intrinsically safe variant and the application of an alternative gasket material of the enclosure.

The future marking reads

 II 3 G Ex nA II T6 Gc and II 3 D Ex tc IIIC T80 °C Dc

All further specifications of the conformity statement PTB 03 ATEX 2179 X as well as its 1<sup>st</sup> and 2<sup>nd</sup> supplement apply without changes also to this 3<sup>rd</sup> supplement.

### Applied standards

EN 60079-0:2012/A11:2013 EN 60079-15:2010 EN 60079-31:2014

Test report: PTB Ex 16-25126

Zertifizierungssektor Explosionsschutz  
By order:

Braunschweig, April 19, 2016

  
Dr.-Ing. F. Liesch  
Regierungsdirektor



Sheet 1/1

Conformity Statements without signature and official stamp shall not be valid. The certificates may be circulated only without alteration. Extracts or alterations are subject to approval by the Physikalisch-Technische Bundesanstalt. In case of dispute, the German text shall prevail.

Physikalisch-Technische Bundesanstalt • Bundesallee 100 • 38116 Braunschweig • GERMANY

**Installation Manual for apparatus certified by CSA for use in hazardous locations.**

Electrical rating of intrinsically safe apparatus and apparatus for installation in hazardous locations.

**Table 1: Maximum values of signal circuit** (terminals 11 and 12)

	$U_i$ or $V_{max}$	$I_i$ or $I_{max}$	$P_i$ or $P_{max}$	$C_i$	$L_i$
<b>Signal circuit</b>	28V	115mA	1W	5,3nF	0 $\mu$ H

Notes:  $U_0 \leq U_i$  or  $V_{max} / I_0 \leq I_i$  or  $I_{max}$  $P_0$  or  $P_{max} \leq P_i$  or  $P_{max}$ **Table 2: CSA - certified barrier parameters of signal circuit** (terminals 11 and 12)

<b>Barrier</b>	<b>Supply barrier</b>		<b>Evaluation barrier</b>	
	$V_{0C}$	$R_{min}$	$V_{0C}$	$R_{min}$
<b>Signal circuit</b>	$\leq 28V$	$\geq 300\Omega$	28V	Diode

**Table 3:** The correlation between temperature classification and permissible ambient temperature ranges is shown in the table below:

<b>Temperature class</b>	<b>Permissible ambient temperature range</b>
T6	50°C
T5	- 40°C $\leq t_a \leq$ 70°C
T4	80°C

**Intrinsically safe if installed as specified in manufacturer's installation manual.****CSA- certified for hazardous locations****Ex ia IIC T6: Class I, Zone 0****Class II Div. 1, Groups E, F + G, Class III.****Type 4 Enclosure****Notes:**

- 1.) The apparatus may be installed in intrinsically safe circuit only when used in conjunction with CSA certified apparatus. For maximum values of  $U_i$  or  $V_{max}$ ;  $I_i$  or  $I_{max}$ ;  $P_i$  or  $P_{max}$ ;  $C_i$  and  $L_i$  of the various apparatus see Table 1.
- 2.) For barrier selection see Table 2.
- 3.) The installation must be in accordance with the C. E. C. Part 1.
- 4.) Use only supply wires suitable for 5°C above surrounding temperature.
- 5.) For CSA Certification, Safety Barrier must be CSA Certified and installed in accordance with C.E.C. Part. 1. Each pair of I.S. wires must be protected by a shield that is grounded at the I.S. Ground. The shield must extend as close to the terminals as possible.

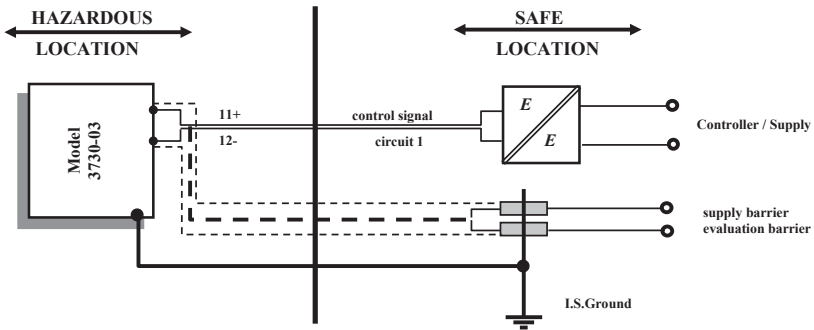

**Controller CSA - certified.  
Supply and evaluation barrier CSA - certified**

For the permissible maximum values for the intrinsically safe circuit see Table 1 or for the permissible barrier parameters for the circuit see Table 2  
Cable entry M 20 x 1.5 or metal conduit according to drawing No. 1050 – 0540 T

**CSA- certified for hazardous locations**

**Ex nA II Class I, Zone 2  
Class II, Div. 2 Groups E, F + G, Class III.**

**Type 4 Enclosure**

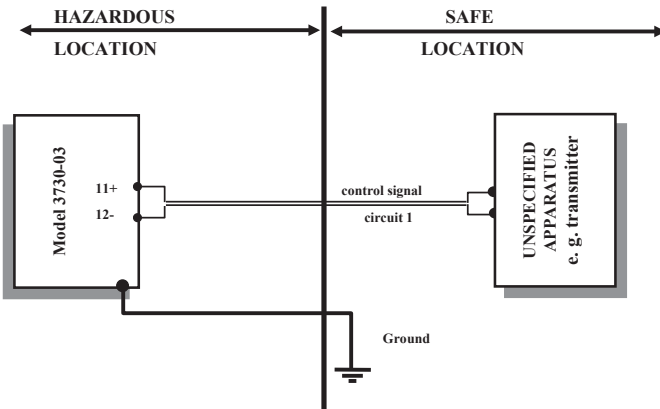

**Notes:**

- 1.) The installation must be in accordance with the Canadian Electrical Code, Part 1
- 2.) For the maximum values for the signal circuit see Table 1 and 2.
- 3.) The cables shall be protected by conduits.
- 4.) Cable entry only rigid metal conduit according to drawing No. 1050-0540 T



**Installation Manual for apparatus approved by FM for use in hazardous locations.**

Electrical rating of intrinsically safe apparatus and apparatus for installation in hazardous locations.

**Table 1: Maximum values**

	U <sub>i</sub> or V <sub>max</sub>	I <sub>i</sub> or I <sub>max</sub>	P <sub>i</sub> or P <sub>max</sub>	C <sub>i</sub>	L <sub>i</sub>
Signal circuit	28V	115mA	1W	5,3nF	0 μH

Notes: U<sub>0</sub> or V<sub>0C</sub> or V<sub>t</sub> ≤ U<sub>i</sub> or V<sub>max</sub> / I<sub>0</sub> or I<sub>0C</sub> or I<sub>t</sub> ≤ I<sub>i</sub> or I<sub>max</sub>  
 P<sub>0</sub> or P<sub>max</sub> ≤ P<sub>i</sub> or P<sub>max</sub>

**Table 2: FM - approved barrier parameters of solenoid valve circuit**

Barrier	Supply barrier			Evaluation barrier		
	V <sub>0C</sub>	R <sub>min</sub>	I <sub>0C</sub>	V <sub>0C</sub>	R <sub>min</sub>	I <sub>0C</sub>
Signal circuit	≤ 28V	≥ 300Ω	≤ 115mA	28V	#	0mA

**Table 3:** The correlation between temperature classification and permissible ambient temperature ranges is shown in the table below:

Temperature class	Permissible ambient temperature range
T6	50°C
T5	- 40°C ≤ ta ≤ 70°C
T4	80°C

**Intrinsically safe if installed as specified in manufacturer’s installation manual.**

**FM- approved for hazardous locations**

**Class I, Zone 0, A Ex ia IIC T6,**

**Class I, II, III, Division 1, Groups A, B, C, D, E, F + G**

**NEMA 4X Enclosure**

**Notes:**

- 1.) The apparatus may be installed in intrinsically safe circuit only when used in conjunction with the FM approved apparatus. For maximum values of U<sub>i</sub> or V<sub>max</sub>; I<sub>i</sub> or I<sub>max</sub>; P<sub>i</sub> or P<sub>max</sub> ; C<sub>i</sub> and L<sub>i</sub> of the various apparatus see Table 1.
- 2.) The apparatus may be installed in intrinsically safe circuit only when used in conjunction with the FM approved intrinsically safe barrier. For barrier selection see Table 2.
- 3.) Installation shall be in accordance with the National Electrical Code ANSI/NFPA 70 and ANSI/ISA RP 12.06.01
- 4.) Use only supply wires suitable for 5°C above surrounding temperature.

**Revision Control Number: 1 February 05**

**Addendum to EB 8384-0 EN**

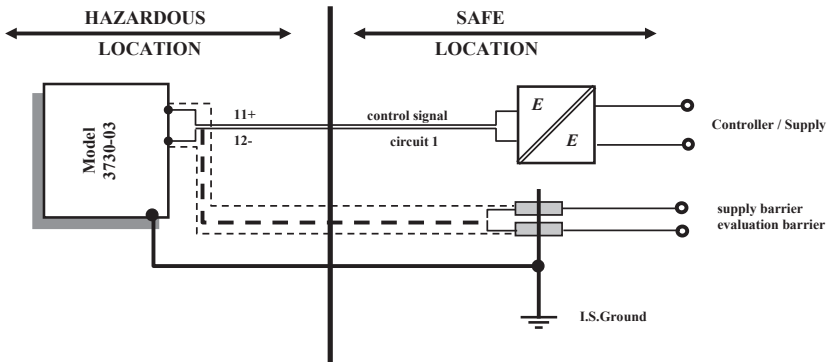

**Version:** Model 3730-03 e/p Positioner.

Supply and evaluation barrier FM/CSA- approved.

For the permissible maximum values for the intrinsically safe circuit see Table 1

For the permissible barrier parameters for the circuit see Table 2

Cable entry M 20 x 1.5 or metal conduit according to drawing No. 1050 – 0540 T

**FM- approved for hazardous locations**

**Class I, Division 2, Groups A, B, C, D**

**Class II Division 2, Groups F + G, Class III**

**NEMA 4X Enclosure**

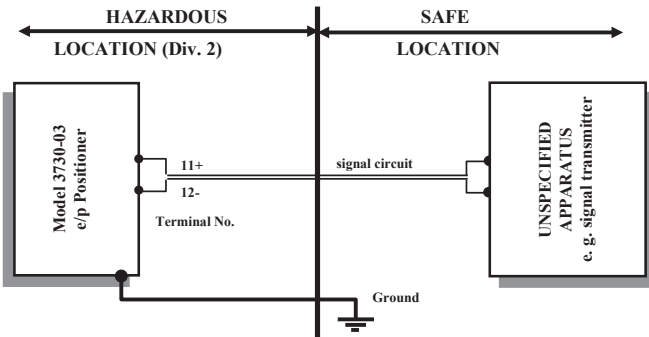

**Notes:**

- 1.) For the maximum values for the circuit see Table 1 and 2.
- 2.) Cable entry only rigid metal conduit according to drawing and 1050-0540 T
- 3.) The installation shall be in accordance with the National Electrical Code ANSI/NFPA 70



## EU Konformitätserklärung / EU Declaration of Conformity / Déclaration UE de conformité

Die alleinige Verantwortung für die Ausstellung dieser Konformitätserklärung trägt der Hersteller/  
This declaration of conformity is issued under the sole responsibility of the manufacturer/  
La présente déclaration de conformité est établie sous la seule responsabilité du fabricant.  
Für das folgende Produkt / For the following product / Nous certifions que le produit

### Elektropneumatischer Stellungsregler / Electropneumatic Positioner / Positionneur électropneumatique Typ/Type/Type 3730-0...

wird die Konformität mit den einschlägigen Harmonisierungsrechtsvorschriften der Union bestätigt /  
the conformity with the relevant Union harmonisation legislation is declared with /  
est conforme à la législation d'harmonisation de l'Union applicable selon les normes:

EMC 2014/30/EU	EN 61000-6-2:2005, EN 61000-6-3:2007 +A1:2011, EN 61326-1:2013
RoHS 2011/65/EU	EN 50581:2012

Hersteller / Manufacturer / Fabricant:

SAMSON AKTIENGESELLSCHAFT  
Weismüllerstraße 3  
D-60314 Frankfurt am Main  
Deutschland/Germany/Allemagne

Frankfurt / Francfort, 2017-07-29

Im Namen des Herstellers/ On behalf of the Manufacturer/ Au nom du fabricant.

*H. Zager*

Hanno Zager  
Leiter Qualitätssicherung/Head of Quality Management/  
Responsable de l'assurance de la qualité

*D. Hoffmann*

Dirk Hoffmann  
Zentralabteilungsleiter/Head of Department/Chef de département  
Entwicklungsorganisation/Development Organization

oe\_3730-0\_de\_en\_fr\_rev07.pdf



## EU Konformitätserklärung / EU Declaration of Conformity / Déclaration UE de conformité

Die alleinige Verantwortung für die Ausstellung dieser Konformitätserklärung trägt der Hersteller/  
This declaration of conformity is issued under the sole responsibility of the manufacturer/  
La présente déclaration de conformité est établie sous la seule responsabilité du fabricant.  
Für das folgende Produkt / For the following product / Nous certifions que le produit

### Elektropneumatischer Stellungsregler / Electropneumatic Positioner / Positionneur électropneumatique Typ/Type/Type 3730-01..

entsprechend der EU-Baumusterprüfbescheinigung PTB 03 ATEX 2099 ausgestellt von der/  
according to the EU Type Examination PTB 03 ATEX 2099 issued by/  
établi selon le certificat CE d'essais sur échantillons PTB 03 ATEX 2099 émis par:

Physikalisch Technische Bundesanstalt  
Bundesallee 100  
D-38116 Braunschweig  
Benannte Stelle/Notified Body/Organisme notifié 0102

wird die Konformität mit den einschlägigen Harmonisierungsrechtsvorschriften der Union bestätigt /  
the conformity with the relevant Union harmonisation legislation is declared with/  
est conforme à la législation d'harmonisation de l'Union applicable selon les normes:

EMC 2014/30/EU	EN 61000-6-2:2005, EN 61000-6-3:2007 +A1:2011, EN 61326-1:2013
Explosion Protection 94/9/EC (bis/to 2016-04-19)	EN 60079-0:2012/A11:2013,
Explosion Protection 2014/34/EU (ab/from 2016-04-20)	EN 60079-11:2012, EN 60079-31:2014
RoHS 2011/65/EU	EN 50581:2012

Hersteller / Manufacturer / Fabricant:

SAMSON AKTIENGESELLSCHAFT  
Weismüllerstraße 3  
D-60314 Frankfurt am Main  
Deutschland/Germany/Allemagne

Frankfurt / Francfort, 2017-07-29

Im Namen des Herstellers/ On behalf of the Manufacturer/ Au nom du fabricant.

Hanno Zager  
Leiter Qualitätssicherung/Head of Quality Management/  
Responsable de l'assurance de la qualité

Dirk Hoffmann  
Zentralabteilungsleiter/Head of Department/Chef du département  
Entwicklungsorganisation/Development Organization



## EU Konformitätserklärung / EU Declaration of Conformity / Déclaration UE de conformité

Die alleinige Verantwortung für die Ausstellung dieser Konformitätserklärung trägt der Hersteller/  
This declaration of conformity is issued under the sole responsibility of the manufacturer/  
La présente déclaration de conformité est établie sous la seule responsabilité du fabricant.  
Für das folgende Produkt / For the following product / Nous certifions que le produit

### Elektropneumatischer Stellungsregler / Electropneumatic Positioner / Positionneur électropneumatique Typ/Type/Type 3730-05..

entsprechend der EU-Baumusterprüfbescheinigung PTB 03 ATEX 2099 ausgestellt von der/  
according to the EU Type Examination PTB 03 ATEX 2099 issued by/  
établi selon le certificat CE d'essais sur échantillons PTB 03 ATEX 2099 émis par:

Physikalisch Technische Bundesanstalt  
Bundesallee 100  
D-38116 Braunschweig  
Benannte Stelle/Notified Body/Organisme notifié 0102

wird die Konformität mit den einschlägigen Harmonisierungsrechtsvorschriften der Union bestätigt /  
the conformity with the relevant Union harmonisation legislation is declared with/  
est conforme à la législation d'harmonisation de l'Union applicable selon les normes:

EMC 2014/30/EU	EN 61000-6-2:2005, EN 61000-6-3:2007 +A1:2011, EN 61326-1:2013
Explosion Protection 94/9/EC (bis/to 2016-04-19)	EN 60079-0:2012/A11:2013,
Explosion Protection 2014/34/EU (ab/from 2016-04-20)	EN 60079-11:2012, EN 60079-31:2014
RoHS 2011/65/EU	EN 50581:2012

Hersteller / Manufacturer / Fabricant:

SAMSON AKTIENGESELLSCHAFT  
Weismüllerstraße 3  
D-60314 Frankfurt am Main  
Deutschland/Germany/Allemagne

Frankfurt / Francfort, 2017-07-29

Im Namen des Herstellers/ On behalf of the Manufacturer/ Au nom du fabricant.

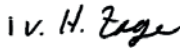

Hanno Zager  
Leiter Qualitätssicherung/Head of Quality Management/  
Responsable de l'assurance de la qualité

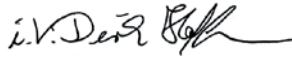

Dirk Hoffmann  
Zentralabteilungsleiter/Head of Department/Chef du département  
Entwicklungsorganisation/Development Organization



## EU Konformitätserklärung / EU Declaration of Conformity / Déclaration UE de conformité

Die alleinige Verantwortung für die Ausstellung dieser Konformitätserklärung trägt der Hersteller/  
This declaration of conformity is issued under the sole responsibility of the manufacturer/  
La présente déclaration de conformité est établie sous la seule responsabilité du fabricant.  
Für das folgende Produkt / For the following product / Nous certifions que le produit

### Elektropneumatischer Stellungsregler / Electropneumatic Positioner / Positionneur électropneumatique Typ/Type/Type 3730-08..

entsprechend der EU-Baumusterprüfbescheinigung PTB 03 ATEX 2179 X ausgestellt von der/  
according to the EU Type Examination PTB 03 ATEX 2179 X issued by/  
établi selon le certificat CE d'essais sur échantillons PTB 03 ATEX 2179 X émis par:

Physikalisch Technische Bundesanstalt  
Bundesallee 100  
D-38116 Braunschweig  
Benannte Stelle/Notified Body/Organisme notifié 0102

wird die Konformität mit den einschlägigen Harmonisierungsrechtsvorschriften der Union bestätigt /  
the conformity with the relevant Union harmonisation legislation is declared with/  
est conforme à la législation d'harmonisation de l'Union applicable selon les normes:

EMC 2014/30/EU	EN 61000-6-2:2005, EN 61000-6-3:2007 +A1:2011, EN 61326-1:2013
Explosion Protection 94/9/EC (bis/to 2016-04-19)	EN 60079-0:2012/A11:2013,
Explosion Protection 2014/34/EU (ab/from 2016-04-20)	EN 60079-15:2010, EN 60079-31:2014
RoHS 2011/65/EU	EN 50581:2012

Hersteller / Manufacturer / Fabricant:

SAMSON AKTIENGESELLSCHAFT  
Weismüllerstraße 3  
D-60314 Frankfurt am Main  
Deutschland/Germany/Allemagne

Frankfurt / Francfort, 2017-07-29

Im Namen des Herstellers/ On behalf of the Manufacturer/ Au nom du fabricant.

Hanno Zager  
Leiter Qualitätssicherung/Head of Quality Management/  
Responsable de l'assurance de la qualité

Dirk Hoffmann  
Zentralabteilungsleiter/Head of Department/Chef du département  
Entwicklungsorganisation/Development Organization



**EB 8384-0 EN**



SAMSON AKTIENGESELLSCHAFT  
Weismüllerstraße 3 · 60314 Frankfurt am Main, Germany  
Phone: +49 69 4009-0 · Fax: +49 69 4009-1507  
samson@samson.de · [www.samson.de](http://www.samson.de)