



SH 8384-1 EN

Translation of original instructions



Type 3730-1 Electropneumatic Positioner

Definition of signal words

DANGER

Hazardous situations which, if not avoided, will result in death or serious injury

WARNING

Hazardous situations which, if not avoided, could result in death or serious injury

NOTICE

Property damage message or malfunction

Note

Additional information

Tip

Recommended action

Purpose of this manual

The Safety Manual SH 8384-1 contains information relevant for the use of the Type 3730-1 Positioner in safety-instrumented systems according to IEC 61508 and IEC 61511. The safety manual is intended for planners, constructors and operators of safety-instrumented systems.

! NOTICE

Risk of malfunction due to incorrect mounting, connection or start-up of the device.

- ➔ *Refer to the Mounting and Operating Instructions EB 8384-1 on how to mount the positioner, perform the electric and pneumatic connections as well as start up the positioner.*
 - ➔ *Observe the warnings and safety instructions written in the Mounting and Operating Instructions EB 8384-1.*
-

Further documentation

The documents listed below contain descriptions of the start-up, functioning and operation of the positioner. You can download these documents from the SAMSON website.

Type 3730-1 Positioner

- ▶ T 8384-1: Data Sheet
 - ▶ EB 8384-1: Mounting and Operating Instructions
-

i Note

In addition to the positioner documentation, observe the documentation for the pneumatic actuator, valve and other valve accessories.

Contents

1	Scope	5
1.1	General	5
1.2	Use in safety-instrumented systems	5
1.3	Versions and ordering data	5
1.4	Attachment.....	6
2	Technical data (excerpt from EB 8384-1)	6
3	Safety-related functions	8
3.1	Fail-safe action	8
3.2	Protection against unauthorized changes to the configuration	8
4	Mounting, connection and start-up.....	10
5	Required conditions.....	10
5.1	Selection	11
5.2	Mechanical and pneumatic installation	11
5.3	Electrical installation.....	12
6	Proof testing (periodic).....	12
6.1	Visual inspection to avoid systematic failure	13
6.2	Function testing.....	13
7	Maintenance and repair	14
8	Safety-related data and certificates	15

1 Scope

1.1 General

The Type 3730-1 Electropneumatic Positioner is a single-acting positioner for mounting on pneumatic rotary and linear actuators with spring-return mechanism. The positioner is used to position control valves.

1.2 Use in safety-instrumented systems

Observing the requirements of IEC 61508, the systematic capability of the pilot valve for emergency venting as a component in safety-instrumented systems is given.

Use of the positioner is possible on observing the requirements of IEC 61511 and the required hardware fault tolerance in safety-instrumented systems up to SIL 2 (single device/HFT = 0) and SIL 3 (redundant configuration/HFT = 1).

The positioner is regarded as a type A device according to IEC 61508-2 in view of its safety functions.

1.3 Versions and ordering data

All versions of the Type 3730-1 Positioner are suitable for use in safety-instrumented systems. The **optional inductive limit contact** implements the safety-related end position monitoring.

The article code written on the nameplate provides details on the optional equipment of the positioner:

Positioner	Type 3730-1 x x 0 0 0 0 0 0 0 x 0 0 x 0 0 0
Option: Inductive limit contact	
Without	0
With SJ2-SN proximity switch (NC contact)	1

Technical data (excerpt from EB 8384-1)

1.4 Attachment

The positioner is suitable for the following types of attachment in combination with various mounting parts:

- Direct attachment to SAMSON Type 3277 Linear Actuators
- Attachment to linear actuators according to IEC 60534-6 (NAMUR)
- Attachment to linear actuators according to VDI/VDE 3847
- Attachment to SAMSON Type 3510 Micro-flow Valve
- Attachment to rotary actuators according to VDI/VDE 3845, fixing levels 1 and 2

2 Technical data (excerpt from EB 8384-1)

Type 3730-1 Positioner The technical data for the explosion-protected devices may be restricted by the limits specified in the test certificates.	
Set point w	Signal range 4 to 20 mA · Two-wire device with reverse polarity protection Split-range operation 4 to 11.9 mA and 12.1 to 20 mA, static destruction limit 100 mA
Minimum current	3.7 mA
Load impedance	≤ 6 V (corresponding to 300 Ω at 20 mA)
Supply Air quality acc. to ISO 8573-1	Supply air: 1.4 to 7 bar (20 to 105 psi) Max. particle size and density: Class 4 · Oil content: Class 3 · Pressure dew point: Class 3 or at least 10 K below the lowest ambient temperature to be expected
Signal pressure (output)	0 bar up to the supply pressure · Can be limited to approx. 2.4 bar by software
Hysteresis	≤ 1 %
Sensitivity	≤ 0.1 %
Air consumption, steady state	Independent from supply pressure approx. 110 l_n/h
Air output capacity Actuator (supply) Actuator (exhaust)	At $\Delta p = 6$ bar: 8.5 m_n^3/h · At $\Delta p = 1.4$ bar: 3.0 m_n^3/h · $K_{Vmax(20^\circ C)} = 0.09$ At $\Delta p = 6$ bar: 14.0 m_n^3/h · At $\Delta p = 1.4$ bar: 4.5 m_n^3/h · $K_{Vmax(20^\circ C)} = 0.15$
Permissible ambient temperature	–20 to +80 °C for all versions –45 to +80 °C with metal cable gland The temperature limits for the explosion-protected devices may be restricted by the limits specified in the test certificates.

Type 3730-1 Positioner The technical data for the explosion-protected devices may be restricted by the limits specified in the test certificates.	
Influences	Temperature: $\leq 0.15\%/10\text{ K}$ Supply air: None Effect of vibration: $\leq 0.25\%$ of 15 to 1500 Hz and 4 g according to IEC 770
Use in safety-instrumented systems (SIL)	Observing the requirements of IEC 61508, the systematic capability of the pilot valve for emergency venting as a component in safety-instrumented systems is given.
	Use is possible on observing the requirements of IEC 61511 and the required hardware fault tolerance in safety-instrumented systems up to SIL 2 (single device/HFT = 0) and SIL 3 (redundant configuration/HFT = 1).
Option: inductive limit contact by Pepperl+Fuchs	
For connection to switching amplifier according to EN 60947-5-6. Can be used in combination with a software limit contact.	
Proximity switch	SJ2-SN
	Measuring plate not detected: $\geq 3\text{ mA}$ · Measuring plate detected: $\leq 1\text{ mA}$

3 Safety-related functions

Emergency venting over the i/p converter (Fig. 1 path —————)

In automatic mode, the PD controller (3) compares the valve position to the DC control signal from 4 to 20 mA issued by the microcontroller. In case of a system deviation, the activation of the i/p converter is changed so that the actuator (1) is either vented or supplied with air. Fail-safe action is triggered and the actuator is vented when no signal (0 mA) is applied to terminals 11/12 and, as a result, to the i/p converter.

Safety-related end position monitoring over the optional inductive limit contact

(Fig. 1 path ————)

The inductive limit contact SJ2-SN (NAMUR NC contact) indicates the adjusted end position in a safety-instrumented system at terminals 44/45. See ► EB 8384-1 for adjusting the limit contacts.

3.1 Fail-safe action

Fail-safe action is triggered by the i/p converter and upon supply air failure. The positioner fully discharges its pneumatic output to the atmosphere, causing the mounted actuator to be vented. As a result, the valve moves to the fail-safe position. The fail-safe position depends on how the springs are arranged in the pneumatic actuator (air-to-close or air-to-open).

3.2 Protection against unauthorized changes to the configuration

A change to the configuration cannot affect the safety function nor cause it to be deactivated.

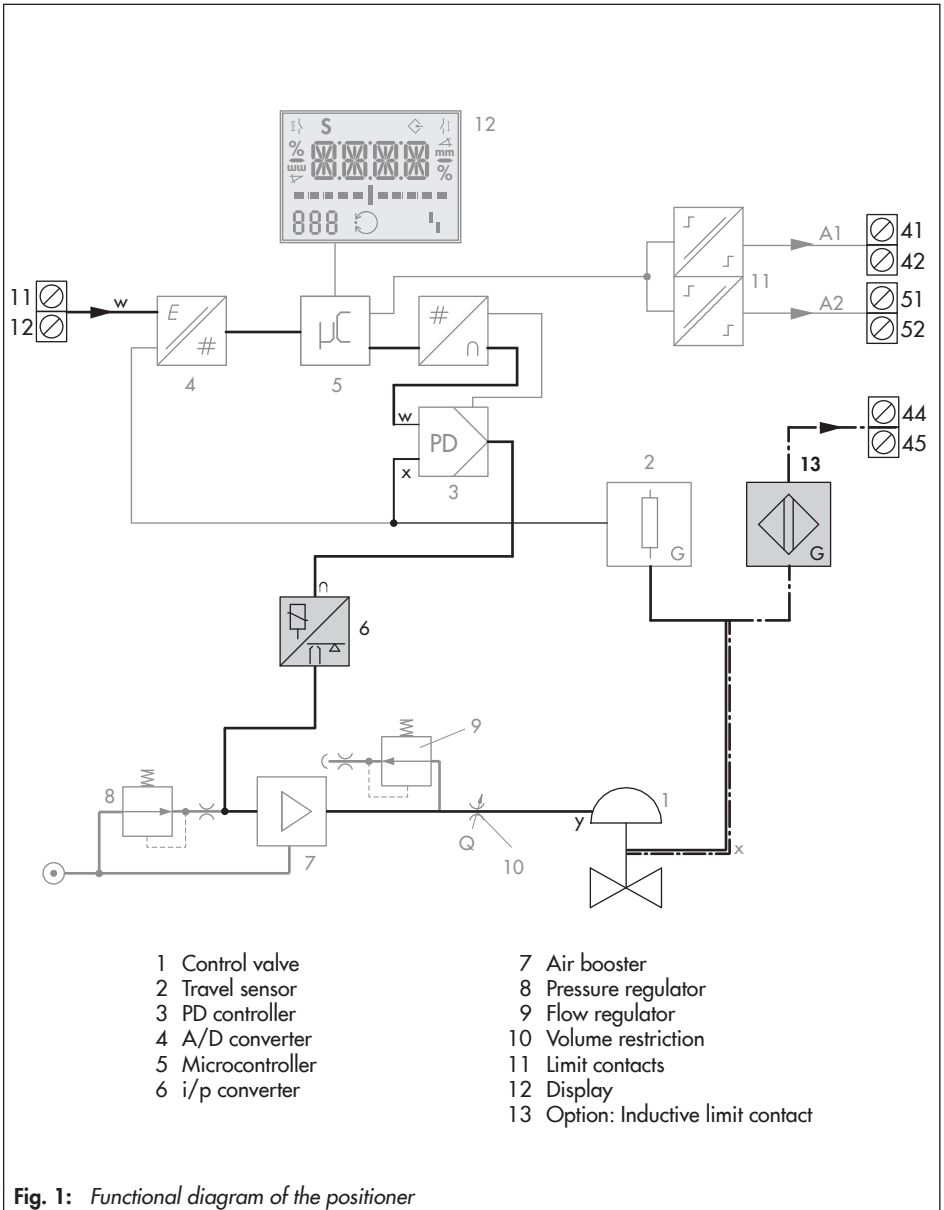

4 Mounting, connection and start-up

Refer to Mounting and Operating Instructions ► EB 8384-1 on how to mount, perform the electric and pneumatic connections as well as start up the positioner.

Only use the specified original mounting parts and accessories.

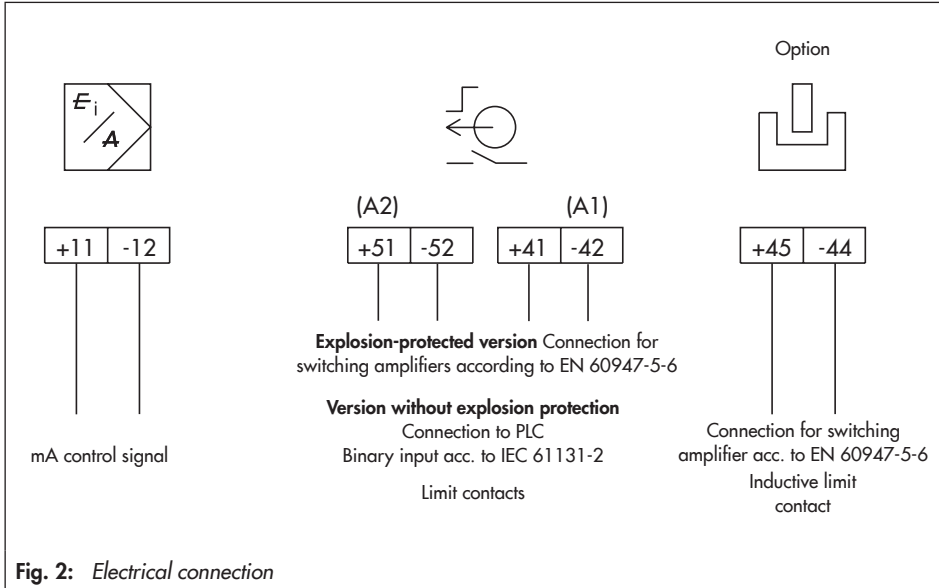

5 Required conditions

⚠ WARNING

Risk of malfunction due to incorrect selection or wrong installation and operating conditions.

→ Only use control valves in safety-instrumented systems if the necessary conditions in the plant are fulfilled. The same applies to the mounted positioner.

5.1 Selection

- The required transit times of the control valve are observed.
The transit times to be implemented are determined by the process engineering requirements.
- The positioner is suitable for the prevailing ambient temperature.

Versions	Temperature range
All	-20 to +80 °C
With metal cable gland	-45 to +80 °C
The temperature limits for the explosion-protected devices may be further restricted by the limits specified in the test certificates.	

- The temperature limits are observed.

5.2 Mechanical and pneumatic installation

- The positioner is mounted properly as described in the mounting and operating instructions and connected to the air supply.
- The maximum supply pressure does not exceed 7 bar.
- The pneumatic air supply meets the instrument air specifications.

Particle size and quantity	Oil content	Pressure dew point
Class 4	Class 3	Class 3
≤ 5 µm and 1000/m ³	≤ 1 mg/m ³	or at least 10 K below the lowest ambient temperature to be expected

Tip

We recommend installing a supply pressure regulator/filter upstream of the positioner. For example, the SAMSON Type 4708 Supply Pressure Regulator with 5 µm filter cartridge can be used.

- The supply air line has a minimum inside diameter of 4 mm.
Select the cross section and length of the line to ensure that the supply pressure at the positioner on supplying air to the actuator does not fall below the minimum limit.
- The positioner is mounted as prescribed.
- The vent opening at the back of the positioner remains open when the positioner is installed on site.

5.3 Electrical installation

- The positioner is connected to the electric power supply properly as described in the mounting and operating instructions.
- Only cables whose outside diameters are suitable for the cable glands are used.
- The electrical cables in Ex i circuits comply with the data that planning was based on.
- The cable glands and cover screws are fastened tightly to ensure that the degree of protection is met.
- The installation requirements for the applicable explosion protection measures are observed.
- The special conditions specified in the explosion protection certificates are observed.

6 Proof testing (periodic)

The proof test interval and the extent of testing lie within the operator's responsibility. The operator must draw up a test plan, in which the proof tests and the interval between them are specified. We recommend summarizing the requirements of the proof test in a checklist.

WARNING

Risk of dangerous failure due to malfunction in the event of emergency (actuator is not vented or the valve does not move to the fail-safe position).

- *Only use devices in safety-instrumented systems that have passed the proof test according to the test plan drawn up by the operator.*

Regularly check the safety-instrumented function of the entire SIS loop. The test intervals are determined, for example on calculating each single SIS loop in a plant (PFD_{avg}).

6.1 Visual inspection to avoid systematic failure

To avoid systematic failure, inspect the positioner regularly. The frequency and the scope of the inspection lie within the operator's responsibility. Take application-specific influences into account, such as:

- Dirt blocking the pneumatic connections
- Corrosion (destruction primarily of metals due to chemical and physical processes)
- Material fatigue
- Aging (damage caused to organic materials, e.g. plastics or elastomers, by exposure to light and heat)
- Chemical attack (organic materials, e.g. plastics or elastomer, which swell, leach out or decompose due to exposure to chemicals)

! NOTICE

Risk of malfunction due to the use of unauthorized parts.

→ Only use original parts to replace worn parts.

6.2 Function testing

Regularly check the safety function according to the test plan drawn up by the operator.

i Note

Record any positioner faults and e-mail (aftersaleservice@samsongroup.com) them to SAMSON.

Emergency venting by applying a 0 mA signal to terminals 11/12 (control signal):

1. Supply the positioner with air within the permissible supply pressure range (max. 7 bar) which allows the valve to move to the maximum travel/angle of rotation.
2. Connect an electric input signal ≥ 3.6 mA to the positioner (terminals 11/12).
3. Switch the positioner to automatic mode (if it has not already been done).
4. Set the input signal (terminals 11/12) over a local current source or over the control system in such a way that the valve moves to the operating position. Check whether the valve moves to this position.
5. Set the electric input signal to 0 mA or disconnect it.
This must cause the valve to move to its fail-safe position (terminals 11/12).

Maintenance and repair

6. Check whether the actuator is fully vented within the demanded time.
7. Set the input signal (terminals 11/12) over a local current source or over the control system in such a way that the valve moves to the approx. 50 % of its travel/angle of rotation. Check whether the valve moved to this position.
8. Set the electric input signal to 0 mA or disconnect it.
This must cause the valve to move to its fail-safe position (terminals 11/12).
9. Check whether the actuator is fully vented within the demanded time.



Tip

Connect a pressure gauge to check that the actuator has completely vented.

Safety-related end position monitoring

10. Supply the positioner with air within the permissible supply pressure range (max. 7 bar) which allows the valve to move to the maximum travel/angle of rotation.
11. Connect an electric input signal ≥ 3.6 mA to the positioner (terminals 11/12).
12. Switch the positioner to automatic mode (if it has not already been done).
13. Set the input signal (terminals 11/12) over a local current source or over the control system in such a way that the valve moves to 50 % of its travel/angle of rotation.
14. Set the input signal (terminals 11/12) over a local current source or over the control system in such a way that the valve moves to the end position.
15. Check whether a signal is issued at terminals 44/45 when the valve has reached the end position.

Proof test

A full stroke test must be performed as the proof test. The following value can be used for Proof Test Coverage to calculate PFD_{avg} :

PTC (Proof Test Coverage) = 92 % for a proof test

7 Maintenance and repair

Only perform the work on the positioner described in ► EB 8384-1.

NOTICE

Fail-safe action impaired due to incorrect repair.

→ Service and repair work must be performed by trained staff only.

For devices operated in the low demand mode (LDM), a useful lifetime of 11 years (plus 1.5 years storage time) is confirmed by TÜV Rheinland® from the date of manufacture while taking into account the specific conditions of use specified in the Safety Manual and the Mounting and Operating Instructions.

The results of the proof test must be assessed and the maintenance scheduled based on it. In particular, after changes (e.g. signs of ageing in elastomers, changed switching times or leakage etc.), it is essential that the manufacturer performs maintenance or repair work on the device.

MTC (Maintenance Coverage) > 99 %

8 Safety-related data and certificates

The safety-related data are listed in the following certificate.

Certificate



SIL/PL
Capability

www.tuv.com
ID 060000000

No.: 968/V 1161.00/20

Product tested Electro pneumatic positioners **Certificate holder** SAMSON AG
Weismüllerstr. 3
60314 Frankfurt / Main
Germany

Type designation 3730-0, 3730-1, 3730-2, 3730-3, 3730-4, 3730-5,
3730-6, TROVIS SAFE 3730-6
3731-3, TROVIS SAFE 3731-3, 3731-5

Codes and standards IEC 61508 Parts 1-2 and 4-7:2010

Intended application Safety Function: Safe venting (and safe indication of the end positions)

The positioners are suitable for use in a safety instrumented system up to SIL 2 (low demand mode).
Under consideration of the minimum required hardware fault tolerance $HFT = 1$ the positioners may be used in a redundant architecture up to SIL 3 according to IEC 61508 and IEC 61511:2016 + AMD1:2017.

Specific requirements The instructions of the associated Installation, Operating and Safety Manual shall be considered.

Summary of test results see back side of this certificate.

Valid until 2025-05-04

The issue of this certificate is based upon an examination, whose results are documented in Report No. 968/V 1161.00/20 dated 2020-05-04.
This certificate is valid only for products which are identical with the product tested.

TÜV Rheinland Industrie Service GmbH
Bereich Automation
Funktionale Sicherheit
Am Grauen Stein, 51105 Köln

Köln, 2020-05-04

Certification Body Safety & Security for Automation & Grid

Dipl.-Ing. Gebhard Bouwer

TÜV Rheinland Industrie Service GmbH, Am Grauen Stein, 51105 Köln / Germany
Tel.: +49 221 806-1700, Fax: +49 221 806-6330, E-Mail: IndustrieService@tuv.com

www.fs-products.com
www.tuv.com

 **TÜVRheinland®**
Precisely Right.

Holder: **SAMSON AG**
 Weilmüllerstraße 3
 60314 Frankfurt am Main
 Germany

Product tested: **Electropneumatic positioners**
 3730-0, 3730-1, 3730-2, 3730-3, 3730-4, 3730-5,
 3730-6³, TROVIS SAFE 3730-6³
 3731-3⁴, TROVIS SAFE 3731-3⁴, 3731-5

Results of Assessment

Hardware Fault Tolerance	HFT	0
Route of Assessment		2H / 1S
Type of Sub-system		Type A
Mode of Operation		Low Demand Mode

Safe venting via lip-converter- all above mentioned types with or without

Lambda Dangerous Undetected ¹	λ_{DU}	9.58 E-08 / h	96 FIT
Average Probability of Failure on Demand ²	$PFD_{avg}(T_i)$	4.19 E-04	

Safe venting via forced venting (3730-6, TROVIS SAFE 3730-6)

Lambda Dangerous Undetected ¹	λ_{DU}	9.58 E-08 / h	96 FIT
Average Probability of Failure on Demand ²	$PFD_{avg}(T_i)$	4.19 E-04	

Safe venting solenoid valve (3730-2, 3730-3, 3730-4, 3730-5, 3730-6, TROVIS SAFE 3730-6)

Lambda Dangerous Undetected ¹	λ_{DU}	8.83 E-08 / h	85 FIT
Average Probability of Failure on Demand ²	$PFD_{avg}(T_i)$	3.87 E-04	

Safe Indication of the end positions (3730-1, 3730-2, 3730-3, 3730-4, 3730-5, 3730-6, TROVIS SAFE 3730-6)

Lambda Dangerous Undetected ¹	λ_{DU}	7.43 E-08 / h	74 FIT
Average Probability of Failure on Demand ²	$PFD_{avg}(T_i)$	3.26 E-04	

¹ assumed Diagnostic Coverage DC = 0 %

² assumed Proof Test Interval T_i = 1 year

³ The types 3730-6 and TROVIS SAFE 3730-6 optionally have switch-off thresholds of < 3.8 mA or < 4.4 mA

⁴ The types 3731-3 and TROVIS SAFE 3731-3 optionally have switch-off thresholds of < 3.8 mA

Origin of values

The stated failure rates are the result of an FMEDA with tailored failure rates for the design and manufacturing process.

Furthermore the results have been verified by qualification tests and field-feedback data of the last 5 years.

Failure rates include failures that occur at a random point in time and are due to degradation mechanisms such as ageing.

The stated failure rates do not release the end-user from collecting and evaluating application-specific reliability data.

Systematic Capability

The development and manufacturing process and the functional safety management applied by the manufacturer in the relevant lifecycle phases of the product have been audited and assessed as suitable for the manufacturing of products for use in applications with a maximum Safety Integrity Level of 3 (SIL 3).

Periodic Tests and Maintenance

The given values require periodic tests and maintenance as described in the Safety Manual.

The operator is responsible for the consideration of specific external conditions (e.g. ensuring of required quality of media, max. temperature, time of impact), and adequate test cycles.

SH 8384-1 EN



SAMSON AKTIENGESELLSCHAFT
Weismüllerstraße 3 · 60314 Frankfurt am Main, Germany
Phone: +49 69 4009-0 · Fax: +49 69 4009-1507
samson@samsongroup.com · www.samsongroup.com