

SAMSON ROTACTOR® RP 3171

Pneumatic rack and pinion actuators
SS AT054U → SS AT654 models

Application

Rotary pneumatic actuators for remote operation (on/off or modulating duties) of industrial valves such as ball valves, butterfly valves and plug valves as used in process industries like chemical, petrochemical, pharmaceutical, oil & gas.

The Samson ROTACTOR RP 3171 stainless steel actuators are available in two configurations: double acting and single acting.

Mechanical Spring Return is for fail-safe applications and can be assembled for "Fail Close" or "Fail Open" safety function.

Double acting actuators can be used for a "Fail Last" Position safety function.

Special features

- 316 stainless steel bodies and end caps, available with or without ENP coating. Polished external surface is an option.
- Dual piston rack and pinion design for compact construction and symmetric mounting.
- Fully machined teeth on piston racks and pinion shaft for accurate positioning, low backlash and maximum engagement.
- Two independent external travel stop adjustments.
- Universal and anti-blowout drive shaft with multiple valve connection options.
- Identical body and end caps for double acting and spring return configuration to allow field conversion.
- Stainless steel fasteners for high corrosion resistance.
- Multiple bearings and guides for high cycles and low friction.
- Modular preloaded springs.
- Extended working temperature range as standard.

Versions

- Spring return: 90° rotation,
- Double acting: 90° rotation.



Fig. 1: ROTACTOR RP 3171 actuators

Further versions

- 100% travel stop limitation in opening direction,
- Fast acting,

Principle of operation

1. DOUBLE ACTING

Refer to Fig.2.

In case of the double acting configuration air pressure is necessary for both strokes (A and B).

2. SINGLE ACTING

Refer to Fig. 3.

When air pressure is supplied through port "2" (A') into the actuator body, the linear force applied on the piston surface generates the pinion rotation, driving the valve to a defined position. At the same time the actuator springs are compressed.

When air pressure is discharged (B'), the springs are automatically released, driving the rack and pistons back to the original position and thus the valve to the fail-safe position.

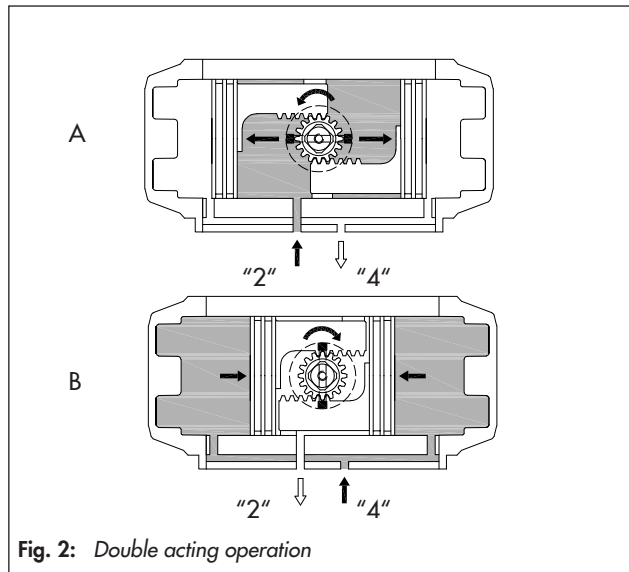

Fig. 2: Double acting operation

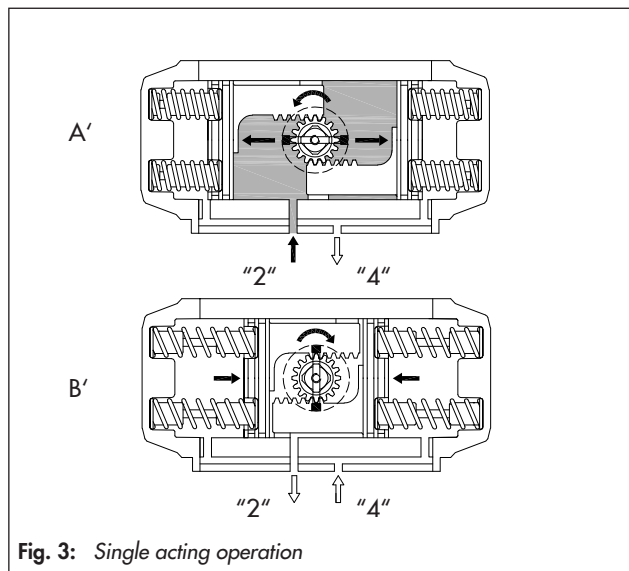

Fig. 3: Single acting operation

Direction of action and stroke adjustment

The standard rotating direction for the Rotactor RP 3171 actuators is clockwise to close. Standard Rotactor RP 3171 actuators are designed for 90° rotating angle, with travel stop

allowing adjustment for -5° up to +5° on the close and open position as per Fig. 4.

For spring return actuator in case of pressure, power or signal failure the springs drive the actuator in the fail position that can be FAIL OPEN or FAIL CLOSE.

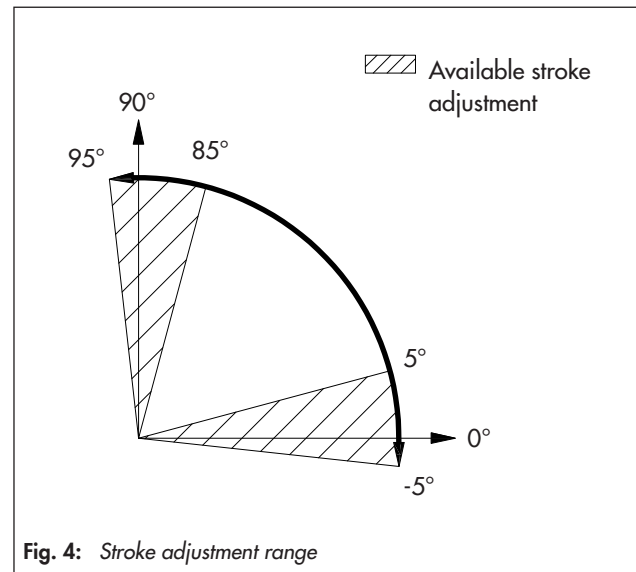

Fig. 4: Stroke adjustment range

Actuators assembly type

- ST: clockwise to close (spring to close) and close indication at air failure condition (or with pressurized port 4 for double acting) for in line mounting. Refer to Fig. 5.
- STR: Clockwise to close (spring to close) and close indication at air failure condition (or with pressurized port 4 for double acting) for across line mounting. Refer to Fig. 5.

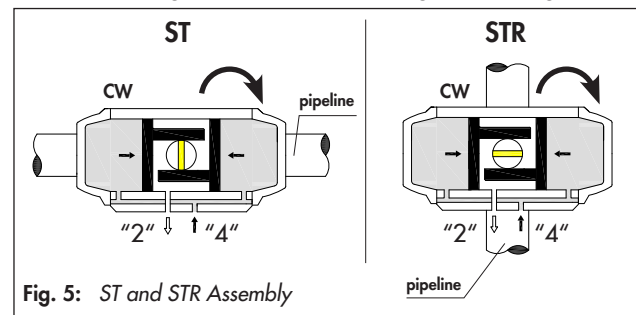

Fig. 5: ST and STR Assembly

- LF: Counterclockwise to close (spring to open) and open indication at air failure condition (or with pressurized port 4 for double acting) for across line mounting. Refer to Fig. 6.
- LFR: Counterclockwise to close (spring to open) and open indication at air failure condition (or with pressurized port 4 for double acting) for in line mounting. Refer to Fig. 6.

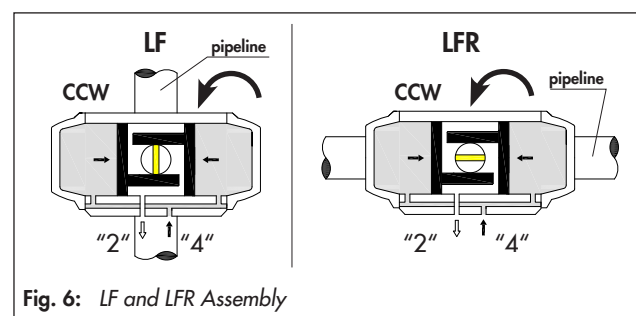

Fig. 6: LF and LFR Assembly

Power operating media

Use dry or lubricated air or inert gas.

- Make sure the operating media is compatible with the actuator internal parts and lubricant.
- In case of pressure medium different than Group 2 fluids according to the PED 2014/68/EU, contact Samson.
- The operating media must have a dew point equal to 20°C (-4°F) or at least 10°C (18°F) below the ambient temperature.
- The maximum particle size contained into the operating media must not exceed 30 µm.

Further information

The actuators can be operated in different ways:

- direct mounting of control devices (for example a solenoid valve or a manifold) with NAMUR interface,
- threaded connections (to pressurize port "2" and "4") with air lines from separate electro-pneumatic control system.

Installation

Refer to the EB 8326-1 EN mounting and operating instructions.

Further versions

- **Extra travel stop limitations (R100/R50)**

R50/R100

Actuator travel stop limitations are available in opening directions for standard assembly (clockwise to close) in order to provide maximum flexibility.

the R50 and R100 allows to limit the actuator stroke in opening direction (from 90° to 0°).

The R50 allow to limit the 45% of the stroke (from 90° to 45° stroke range).

The R100 allow to limit the 100% of the stroke (from 90° to 0° stroke range).

Both R50 and R100 extra travel stop adjustments are equipped with protective plugs at the two adjustment screws ends in order to protect the two ends and to avoid potential cut due to screws sharp edges.

The R50 and R100 can be directly supplied mounted on the actuators or supplied as kits to retrofit sold actuators.

TYPICAL APPLICATION: any application where an extra travel stop opening or closing position is required.

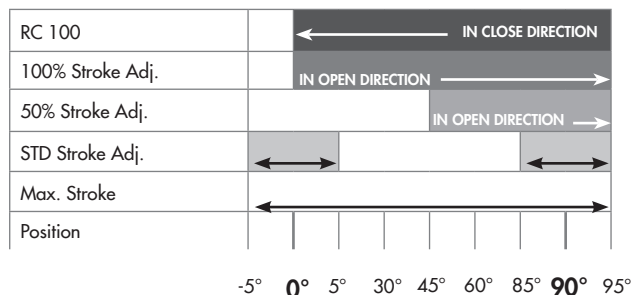

- **Fast acting**

The Fast Acting (FA) actuators are special actuators able to stroke faster respect the standard actuators. They are available both in double acting and in spring return configurations.

This type of actuators has enlarged ports and internal canalization which allows an higher flow rate of the the actuator and so a quicker operation in closing and/or opening direction.

TYPICAL APPLICATION: any application where actuator quick action is required

- **Low and high working temperature configurations**

In case minimum working temperature up to -60°C or maximum working temperature up to +150°C are required, the following special product configuration are available:

- LLT2 version for extreme low operating temperature range:
-60° C (-76° F) → +80° C (+176° F);
- HT version for high operating temperature range:
-15° C (+5° F) → +150° C (+302° F).

TYPICAL APPLICATION: where the required working temperature exceeds the actuator standard working temperature range (-40°C / +80°C)

- **External surface finishing**

Unless defined, the housing in stainless steel is further covered with ENP in order to have minimized friction level. These actuators are also available with polished external surface particularly suitable for Pharma and Food & Beverage applications where a particular surface cleanliness is required. The surface roughness is up to Ra 0,2 micron.

- **Water operated actuator**

The Rotactor RP 3171 actuators are operated with dry air or inert gas. Special actuator configurations are available to operate with water as supply media.

Contact Samson for further detailed information.

- **Natural gas operated actuator**

The Rotactor RP 3171 actuators are operated with dry air or inert gas. Special actuator configurations are available to operate with natural gas (sweet and dry or sour) as supply media.

Contact Samson for further detailed information.

Table 1: SAMSON ROTACTOR RP 3171 - SS AT054U

Table 1.1: Technical data

Max. Pressure	Standard Rotation	Stroke Adjustment Screw	Ø Chamber (inch)	Air volume (in ³)		Approx. Stroking time (sec.) ¹⁾				Operating temperature range (°F) ²⁾		
						Double acting		Spring return				
116 Psi	0° - 90°	For 1° adj. 1/6 Turn needed	1,97	opening	closing	opening	closing	opening	closing	ST	HT	LLT2
				5,5	9,2	0,20	0,25	0,25	0,30	-40 to +176	+5 to +302	-76 to +176

¹⁾ The values refer to specific test conditions; please contact SAMSON for detailed information.

²⁾ Every temperature range option requires proper components and lubricant. please contact SAMSON for detailed information.

Table 1.2: Nominal output torque for Double acting actuators (lb-in)

Pressure	40 Psi		50 Psi		60 Psi		70 Psi		80 Psi		90 Psi		100 Psi		110 Psi		116 Psi		Approx. weight (lb)
	0°	90°	0°	90°	0°	90°	0°	90°	0°	90°	0°	90°	0°	90°	0°	90°	0°	90°	
D	81,1		101		122		142		162		183		203		223		235		6,04

Table 1.3: Nominal output torque for Single acting actuators (lb-in)

Pressure	40 Psi		50 Psi		60 Psi		70 Psi		80 Psi		90 Psi		100 Psi		110 Psi		116 Psi		Spring Stroke	Approx weight (lb)	
	0°	90°	0°	90°	0°	90°	0°	90°	0°	90°	0°	90°	0°	90°	0°	90°	0°	90°			
S 01	51,9	34	72,2	54,4	92,5	74,7	113	94,9	133	115	153	136	174	156					47,1	29,2	6,15
S 02	46,1	24,7	66,3	45,0	86,6	65	107	85,6	127	106	147	126	168	146	188	167			56,5	35,1	
S 03	40,2	15,2	60,5	35,5	81	55,8	101	76,1	121	96	142	117	162	137	182	157	194	169	65,9	40,9	6,20
S 04			54,7	26,1	75	46,3	95,2	67	116	87	136	107	156	127	176	148	189	160	75	46,8	
S 05			48,8	16,7	69	37,0	89,4	57,3	110	78	130	98	150	118	171	138	183	151	84,8	52,6	6,24
S 06					63,3	27,6	83,5	47,9	104	68	124	88,4	144	109	165	129	177	141	94,1	58,5	
S 07					57,4	18,1	77,7	38,4	98,0	58,7	118	79,0	139	99	159	120	171	132	104	64,3	6,28
S 08							71,9	29,0	92,1	49,2	112,4	69,5	133	90	153	110	165	122	113	70,2	

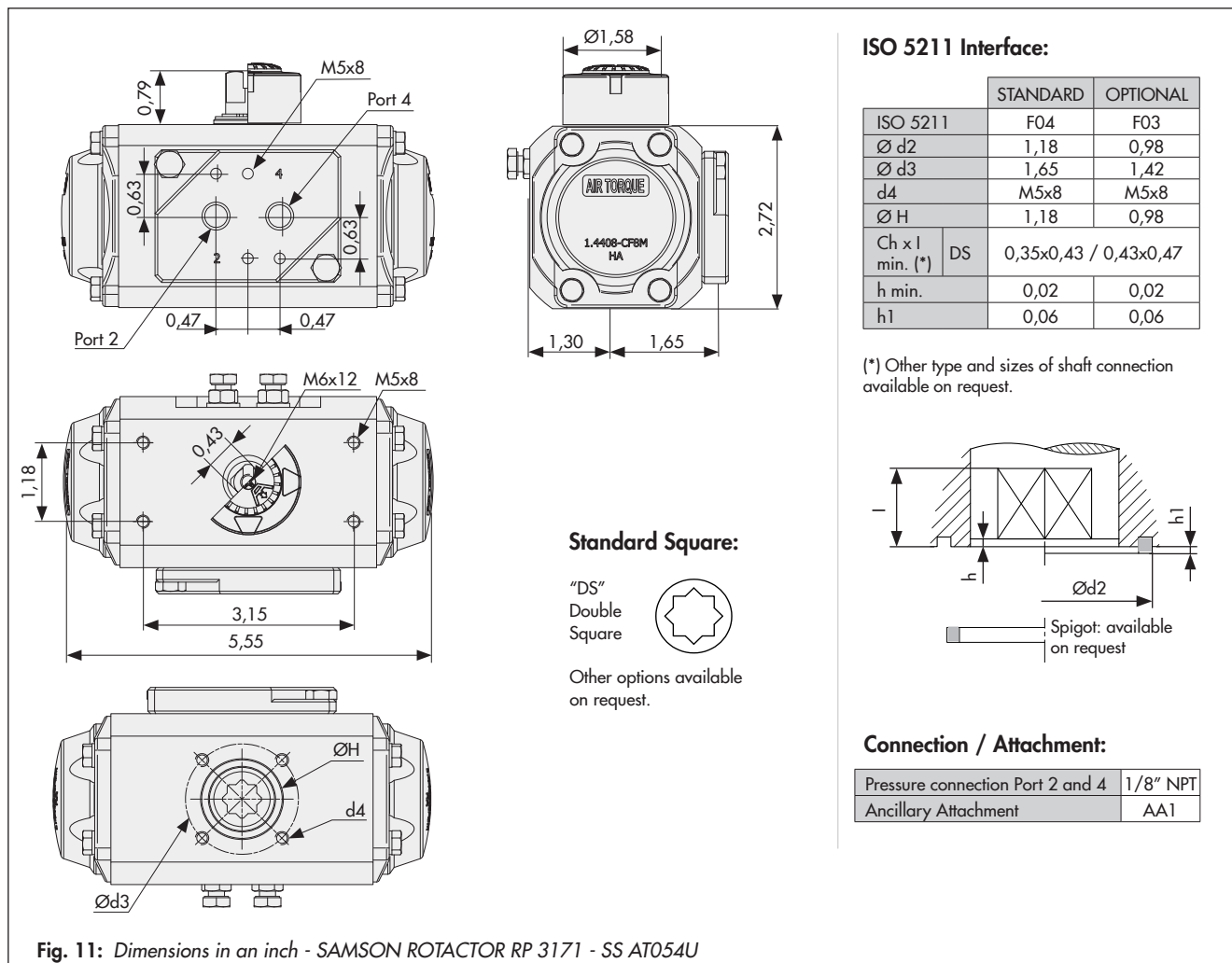

Fig. 11: Dimensions in an inch - SAMSON ROTACTOR RP 3171 - SS AT054U

Table 2: SAMSON ROTACTOR RP 3171 - SS AT104

Table 2.1: Technical data

Max. Pressure	Standard Rotation	Stroke Adjustment Screw	Ø Chamber (in)	Air volume (in ³)		Approx. Stroking time (sec.) ¹⁾				Operating temperature range (°F) ²⁾		
						Double acting		Spring return				
116 Psi	0° - 90°	For 1° adj. 1/6 Turn needed	2,48	opening	closing	opening	closing	opening	closing	ST	HT	LLT2
				9,76	15,86	0,25	0,30	0,30	0,35			

¹⁾ The values refer to specific test conditions; please contact SAMSON for detailed information.

²⁾ Every temperature range option requires proper components and lubricant. please contact SAMSON for detailed information.

Table 2.2: Nominal output torque for Double acting actuators (lb-in)

Pressure	40 Psi		50 Psi		60 Psi		70 Psi		80 Psi		90 Psi		100 Psi		110 Psi		116 Psi		Approx weight (lb)
	0°	90°	0°	90°	0°	90°	0°	90°	0°	90°	0°	90°	0°	90°	0°	90°	0°	90°	
D	143		179		215		251		286		322		358		394		415		8,26

Table 2.3: Nominal output torque for Single acting actuators (lb-in)

Pressure	40 Psi		50 Psi		60 Psi		70 Psi		80 Psi		90 Psi		100 Psi		110 Psi		116 Psi		Spring Stroke	Approx weight (lb)	
	0°	90°	0°	90°	0°	90°	0°	90°	0°	90°	0°	90°	0°	90°	0°	90°	0°	90°			
S 05	94	68,5	130	104	166	140	201	176	237	212	273	247	309	283					74,7	49,1	8,47
S 06	84,2	53,5	120	89,3	156	125	192	161	227	197	263	232	299	268	335	304			89,6	58,9	
S 07	74,4	38,6	110	74,4	146	110	182	146	218	182	253	218	289	253	325	289	346	311	105	68,8	8,53
S 08			100	59,5	136	95,2	172	131	208	167	243	203	279	238	315	274	337	296	119	78,6	
S 09					126	80,3	162	116	198	152	234	188	269	223	305	259	327	281	134	88,4	8,60
S 10							152	101	188	137	224	173	260	209	295	244	317	266	149	98,2	
S 11									178	122	214	158	250	194	286	229	307	251	164	108	8,67
S 12													240	179	276	214	297	236	179	118	

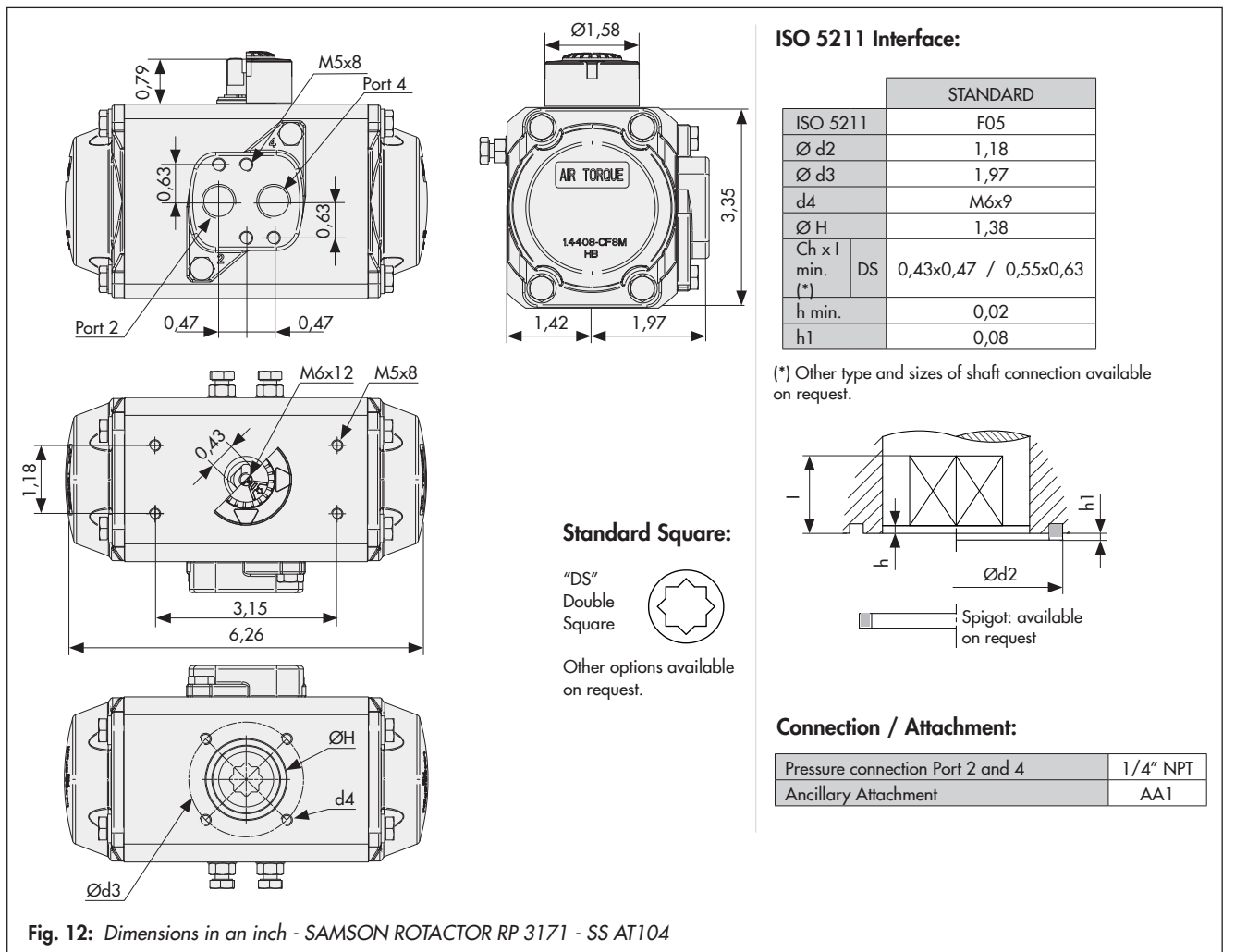

Fig. 12: Dimensions in an inch - SAMSON ROTACTOR RP 3171 - SS AT104

Table 3: SAMSON ROTACTOR RP 3171 - SS AT204

Table 3.1: Technical data

Max. Pressure	Standard Rotation	Stroke Adjustment Screw	Ø Chamber (in)	Air volume (in³)		Approx. Stroking time (sec.) ¹⁾				Operating temperature range (°F) ²⁾		
						Double acting		Spring return				
116 Psi	0° - 90°	For 1° adj. 1/6 Turn needed	2,95	opening	closing	opening	closing	opening	closing	ST	HT	LLT2
				18,91	29,90	0,30	0,35	0,40	0,50	-40 to +176	-5 to +150	-76 to +176

¹⁾ The values refer to specific test conditions; please contact SAMSON for detailed information.

²⁾ Every temperature range option requires proper components and lubricant. please contact SAMSON for detailed information.

Table 3.2: Nominal output torque for Double acting actuators (lb-in)

Pressure	40 Psi		50 Psi		60 Psi		70 Psi		80 Psi		90 Psi		100 Psi		110 Psi		116 Psi		Approx weight (lb)
	0°	90°	0°	90°	0°	90°	0°	90°	0°	90°	0°	90°	0°	90°	0°	90°	0°	90°	
D	284		355		426		497		568		639		710		781		824		13,32

Table 3.3: Nominal output torque for Single acting actuators (lb-in)

Pressure	40 Psi		50 Psi		60 Psi		70 Psi		80 Psi		90 Psi		100 Psi		110 Psi		116 Psi		Spring Stroke	Approx weight (lb)	
	0°	90°	0°	90°	0°	90°	0°	90°	0°	90°	0°	90°	0°	90°	0°	90°	0°	90°			
S 05	186	131	257	202	328	273	399	344	470	415	541	486	612	557					153	97,8	13,74
S 06	167	100	238	171	309	242	380	313	451	384	522	455	593	526	664	597			184	117	
S 07	147	70	218	141	289	212	360	283	431	354	502	425	573	496	644	567	687	609	214	137	13,89
S 08			198	110	269	181	340	252	412	323	483	394	554	465	625	536	667	579	245	157	
S 09					250	150	321	221	392	292	463	363	534	434	605	505	648	548	276	176	14,04
S 10							301	191	372	262	443	333	514	404	585	475	628	517	306	196	
S 11									353	231	424	302	495	373	566	444	608	487	337	215	14,18
S 12													475	342	546	413	589	456	368	235	

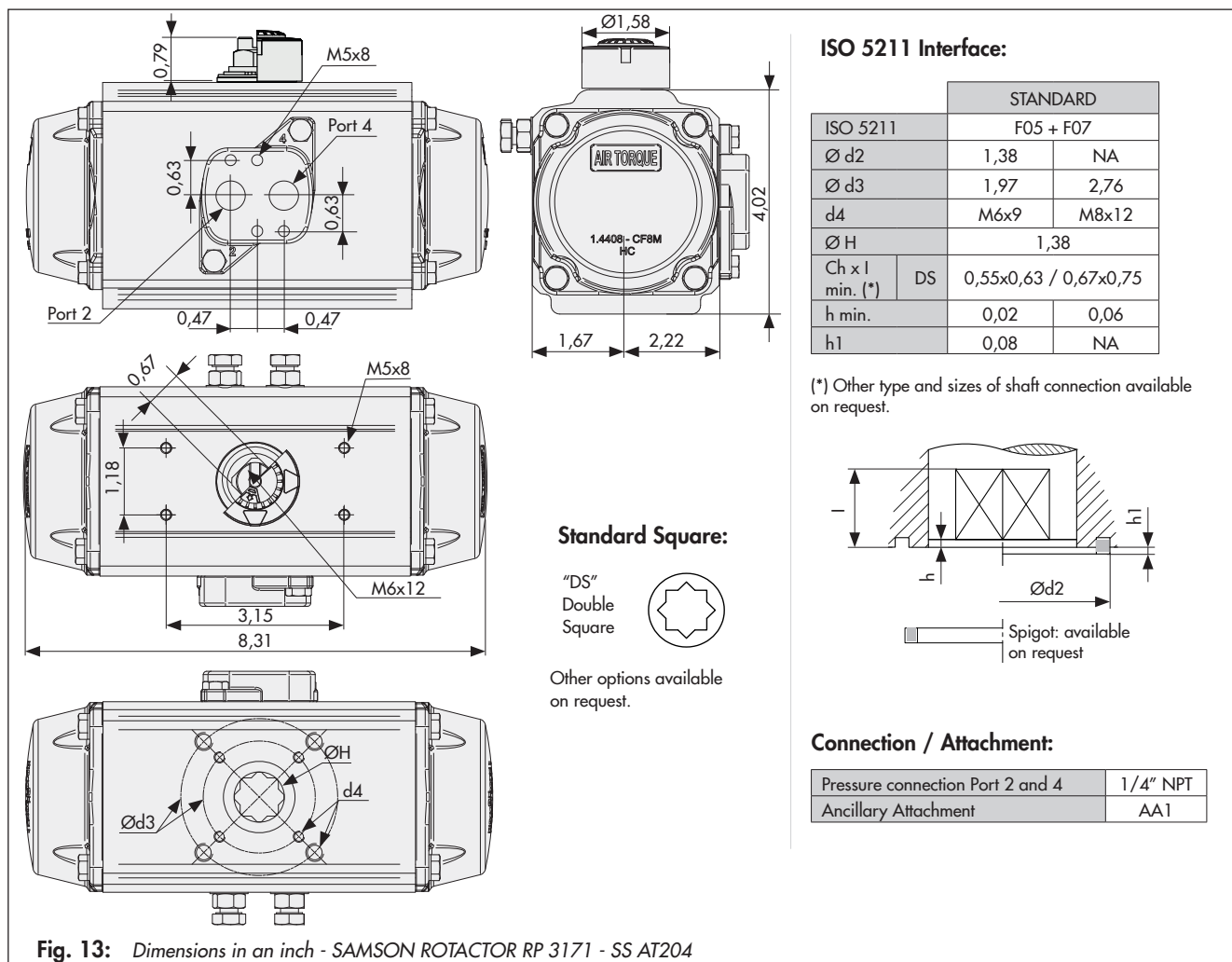

Fig. 13: Dimensions in an inch - SAMSON ROTACTOR RP 3171 - SS AT204

Table 4: SAMSON ROTACTOR RP 3171 - SS AT254

Table 4.1: Technical data

Max. Pressure	Standard Rotation	Stroke Adjustment Screw	Ø Chamber (in)	Air volume (in ³)		Approx. Stroking time (sec.) ¹⁾				Operating temperature range (°F) ²⁾		
						Double acting		Spring return				
116 Psi	0° - 90°	For 1° adj. 1/5 Turn needed	3,46	opening	closing	opening	closing	opening	closing	ST	HT	LLT2
				31,12	47,59	0,40	0,50	0,50	0,60	-40 to +176	-5 to +302	-76 to +176

¹⁾ The values refer to specific test conditions; please contact SAMSON for detailed information.

²⁾ Every temperature range option requires proper components and lubricant. please contact SAMSON for detailed information.

Table 4.2: Nominal output torque for Double acting actuators (lb-in)

Pressure	40 Psi		50 Psi		60 Psi		70 Psi		80 Psi		90 Psi		100 Psi		110 Psi		116 Psi		Approx weight (lb)
	0°	90°	0°	90°	0°	90°	0°	90°	0°	90°	0°	90°	0°	90°	0°	90°	0°	90°	
D	447		559		670		782		894		1005		1117		1229		1296		19,3

Table 4.3: Nominal output torque for Single acting actuators (lb-in)

Pressure	40 Psi		50 Psi		60 Psi		70 Psi		80 Psi		90 Psi		100 Psi		110 Psi		116 Psi		Spring Stroke	Approx weight (lb)	
	0°	90°	0°	90°	0°	90°	0°	90°	0°	90°	0°	90°	0°	90°	0°	90°	0°	90°			
S 05	285	191	396	303	508	415	620	526	731	638	843	750	955	862					256	162	20,0
S 06	252	140	476	252	476	364	587	475	699	587	811	699	922	810	1034	922			307	195	
S 07	220	89	331	201	443	313	555	424	667	536	778	648	890	759	1002	871	1069	938	358	227	20,1
S 08			299	150	411	261	522	373	634	485	746	597	858	708	969	820	1036	887	409	260	
S 09					378	210	490	322	602	434	713	545	825	657	937	769	1004	836	460	292	20,4
S 10							457	271	569	383	681	494	793	606	904	718	971	785	511	325	
S 11									537	331	648	443	760	555	872	667	939	734	562	357	20,6
S 12													728	504	839	616	906	683	613	389	

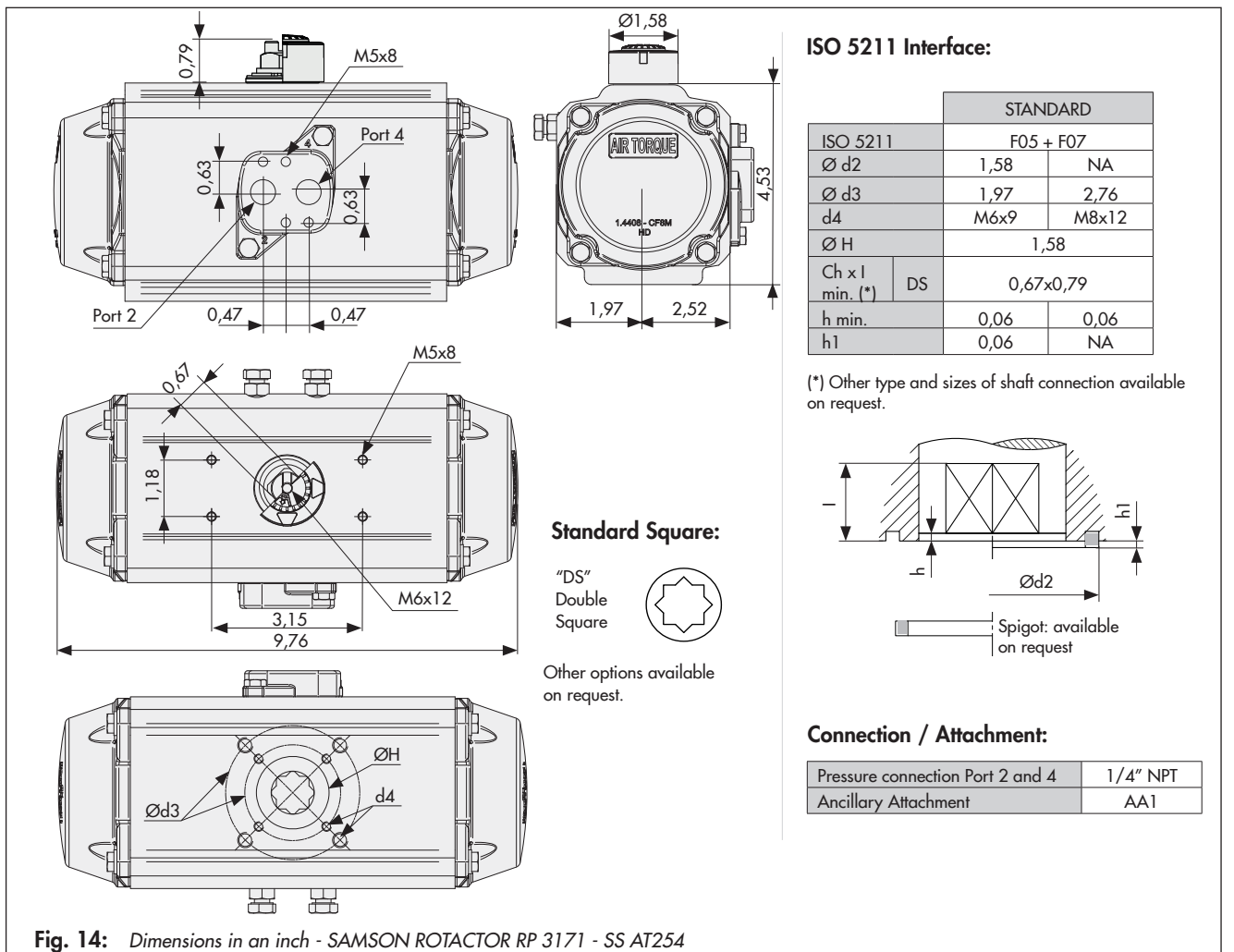

Fig. 14: Dimensions in an inch - SAMSON ROTACTOR RP 3171 - SS AT254

Table 5: SAMSON ROTACTOR RP 3171 - SS AT304

Table 5.1: Technical data

Max. Pressure	Standard Rotation	Stroke Adjustment Screw	Ø Chamber (in)	Air volume (in ³)		Approx. Stroking time (sec.) ¹⁾				Operating temperature range (°F) ²⁾		
						Double acting		Spring return				
116 Psi	0° - 90°	For 1° adj. 1/5 Turn needed	3,94	opening	closing	opening	closing	opening	closing	ST -40 to +176	HT +5 to +302	LLT2 -76 to +176
				43,3	67,7	0,50	0,60	0,70	0,90			

¹⁾ The values refer to specific test conditions; please contact SAMSON for detailed information.

²⁾ Every temperature range option requires proper components and lubricant. please contact SAMSON for detailed information.

Table 5.2: Nominal output torque for Double acting actuators (lb-in)

Pressure	40 Psi		50 Psi		60 Psi		70 psi		80 Psi		90 Psi		100 Psi		110 Psi		116 Psi		Approx weight (lb)
	0°	90°	0°	90°	0°	90°	0°	90°	0°	90°	0°	90°	0°	90°	0°	90°	0°	90°	
D	649		811		974		1136		1298		1461		1623		1785		1883		27,2

Table 5.3: Nominal output torque for Single acting actuators (lb-in)

Pressure	40 Psi		50 Psi		60 Psi		70 psi		80 Psi		90 Psi		100 Psi		110 Psi		116 Psi		Spring Stroke	Approx weight (lb)	
	0°	90°	0°	90°	0°	90°	0°	90°	0°	90°	0°	90°	0°	90°	0°	90°	0°	90°			
S 05	425	301	587	463	750	625	912	787	1074	950	1236	1112	1399	1274					349	224	28,1
S 06	380	231	542	393	705	555	867	718	1029	880	1192	1042	1354	1205	1516	1367			418	269	
S 07	335	161	498	323	660	486	822	648	984	810	1147	973	1309	1135	1471	1297	1569	1395	488	314	28,4
S 08			453	254	615	416	777	578	940	741	1102	903	1264	1065	1426	1227	1524	1325	558	359	
S 09					570	346	732	509	895	671	1057	833	1219	995	1382	1158	1479	1255	627	404	28,8
S 10							688	439	850	601	1012	763	1174	926	1337	1088	1434	1185	697	449	
S 11									805	531	967	694	1130	856	1292	1018	1389	1116	767	493	29,1
S 12													1085	786	1247	949	1344	1046	837	538	

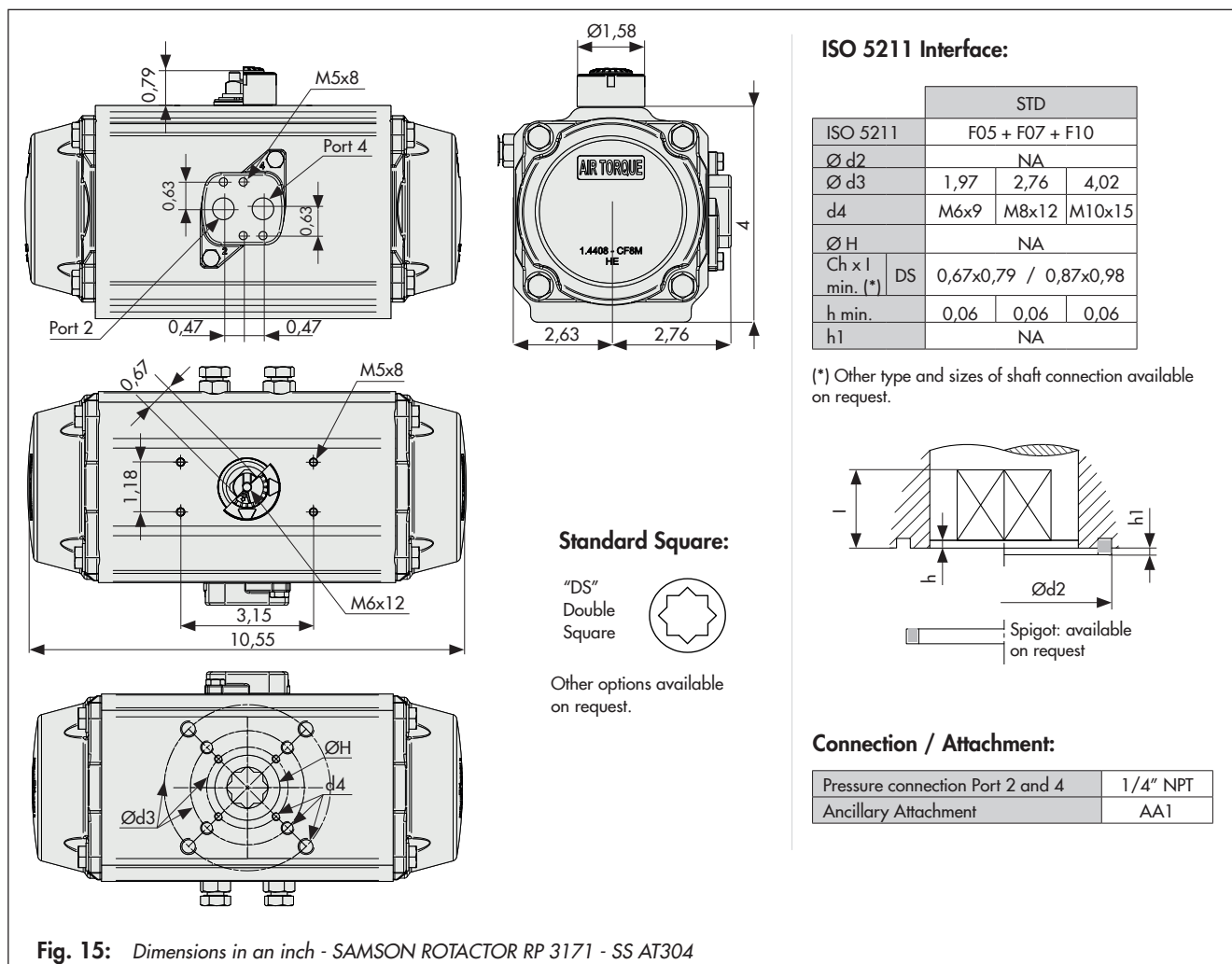

Fig. 15: Dimensions in an inch - SAMSON ROTACTOR RP 3171 - SS AT304

Table 6: SAMSON ROTACTOR RP 3171 - SS AT404

Table 6.1: Technical data

Max. Pressure	Standard Rotation	Stroke Adjustment Screw	Ø Chamber (in)	Air volume (in ³)		Approx. Stroking time (sec.) ¹⁾				Operating temperature range (°F) ²⁾		
						Double acting		Spring return				
116 Psi	0° - 90°	For 1° adj. 1/4 Turn needed	4,92	opening	closing	opening	closing	opening	closing	ST	HT	LLT2
				94	143	0,90	1,10	1,20	1,40	-40 to +176	+5 to +302	-76 to +176

¹⁾ The values refer to specific test conditions; please contact SAMSON for detailed information.

²⁾ Every temperature range option requires proper components and lubricant. please contact SAMSON for detailed information.

Table 6.2: Nominal output torque for Double acting actuators (lb-in)

Pressure	40 Psi		50 Psi		60 Psi		70 Psi		80 Psi		90 Psi		100 Psi		110 Psi		116 Psi		Approx weight (lb)
	0°	90°	0°	90°	0°	90°	0°	90°	0°	90°	0°	90°	0°	90°	0°	90°	0°	90°	
D	1352		1691		2029		2367		2705		3043		3381		3719		3922		46,8

Table 6.3: Nominal output torque for Single acting actuators (lb-in)

Pressure	40 Psi		50 Psi		60 Psi		70 Psi		80 Psi		90 Psi		100 Psi		110 Psi		116 Psi		Spring Stroke	Approx weight (lb)	
	0°	90°	0°	90°	0°	90°	0°	90°	0°	90°	0°	90°	0°	90°	0°	90°	0°	90°			
S 05	888	623	1226	961	1564	1299	1902	1637	2240	1976	2578	2314	2916	2652					729	465	51,8
S 06	795	477	1133	815	1471	1154	1809	1492	2147	1830	2485	2168	2823	2506	3161	2844			875	558	
S 07	702	331	1040	670	1378	1008	1716	1346	2054	1684	2392	2022	2730	2360	3069	2698	3271	2901	1021	651	52,5
S 08			947	524	1285	862	1623	1200	1961	1538	2299	1876	2637	2214	2976	2552	3178	2755	1167	744	
S 09					1192	716	1530	1054	1868	1392	2206	1730	2544	2068	2883	2407	3085	2609	1313	837	53,1
S 10							1437	908	1775	1246	2113	1584	2452	1923	2790	2261	2993	2464	1459	930	
S 11									1682	1100	2020	1439	2359	1777	2697	2115	2900	2318	1604	1023	53,8
S 12													2266	1631	2604	1969	2807	2172	1750	1116	

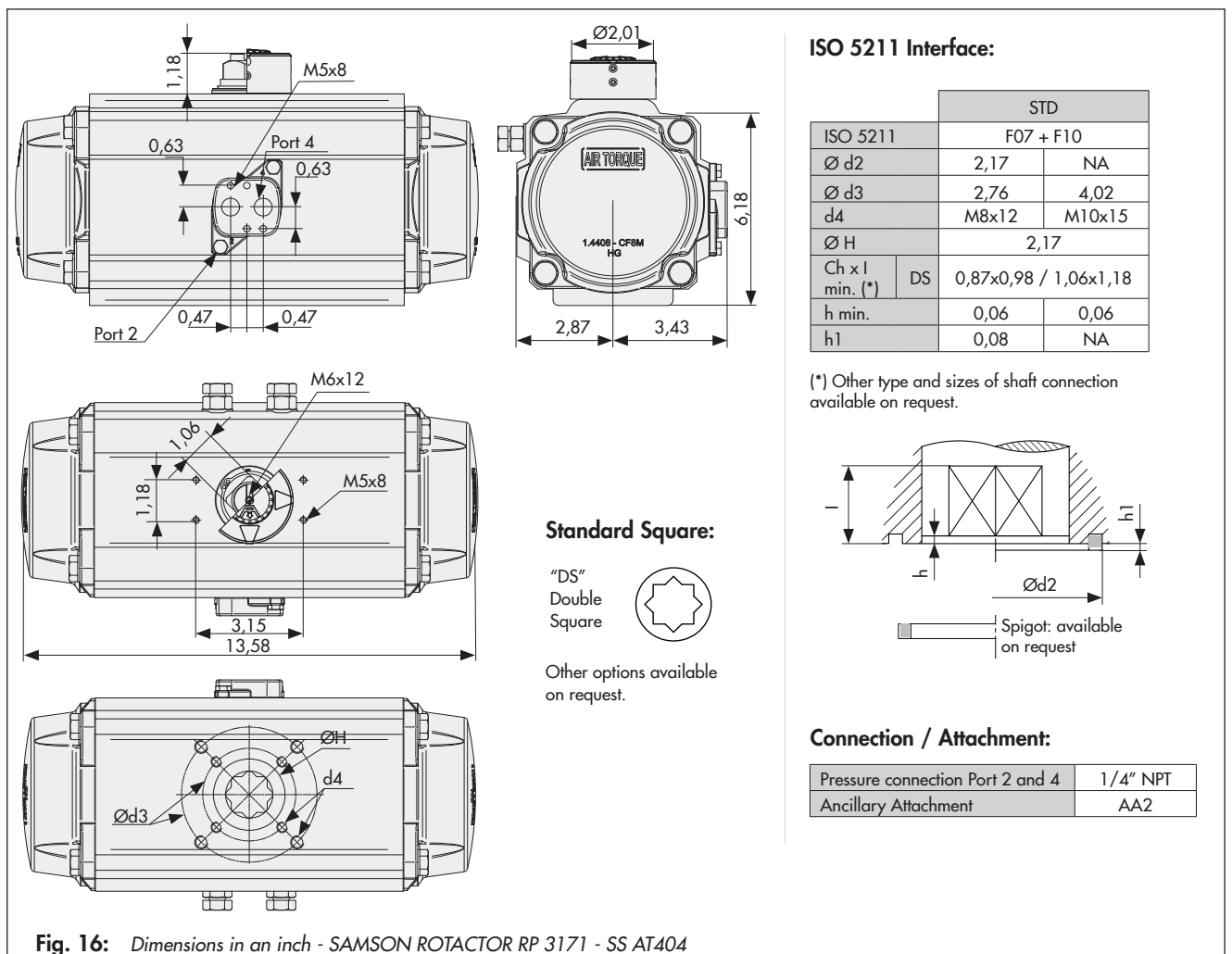

Fig. 16: Dimensions in an inch - SAMSON ROTACTOR RP 3171 - SS AT404

Table 7: SAMSON ROTACTOR RP 3171 - SS AT454

Table 7.1: Technical data

Max. Pressure	Standard Rotation	Stroke Adjustment Screw	Ø Chamber (in)	Air volume (in ³)		Approx. Stroking time (sec.) ¹⁾				Operating temperature range (°F) ²⁾		
						Double acting		Spring return				
116 Psi	0° - 90°	For 1° adj. 1/4 Turn needed	5,71	opening	closing	opening	closing	opening	closing	ST -40 to +176	HT +5 to +302	LLT2 -76 to +176
				1,47	231	1,2	1,4	1,5	1,8			

¹⁾ The values refer to specific test conditions; please contact SAMSON for detailed information.

²⁾ Every temperature range option requires proper components and lubricant. please contact SAMSON for detailed information.

Table 7.2: Nominal output torque for Double acting actuators (lb-in)

Pressure	40 Psi		50 Psi		60 Psi		70 Psi		80 Psi		90 psi		100 Psi		110 Psi		116 Psi		Approx weight (lb)
	0°	90°	0°	90°	0°	90°	0°	90°	0°	90°	0°	90°	0°	90°	0°	90°	0°	90°	
D	2123		2654		3185		3716		4246		4777		5308		5839		6157		76,3

Table 7.3: Nominal output torque for Single acting actuators (lb-in)

Pressure	40 Psi		50 Psi		60 Psi		70 Psi		80 Psi		90 psi		100 Psi		110 Psi		116 Psi		Spring Stroke	Approx weight (lb)	
	0°	90°	0°	90°	0°	90°	0°	90°	0°	90°	0°	90°	0°	90°	0°	90°	0°	90°			
S 05	1394	983	1925	1514	2456	2044	2987	2575	3517	3106	4048	3637	4579	4167					1140	729	79,6
S 06	1248	755	1779	1285	2310	1816	2841	2347	3372	2878	3902	3409	4433	3939	4964	4470			1369	875	
S 07	1103	527	1633	1057	2164	1588	2695	2119	3226	2650	3757	3181	4287	3711	4818	4242	5137	4561	1597	1021	80,7
S 08			1488	829	2018	1360	2549	1891	3080	2422	3611	2952	4142	3483	4672	4014	4991	4333	1825	1166	
S 09					1873	1132	2403	1663	2934	2194	3465	2724	3996	3255	4527	3786	4845	4104	2053	1312	81,8
S 10							2258	1435	2788	1965	3319	2496	3850	3027	4381	3558	4699	3876	2281	1458	
S 11									2643	1737	3173	2268	3704	2799	4235	3330	4553	3648	2509	1604	82,9
S 12													3558	2571	4089	3102	4408	3420	2737	1750	

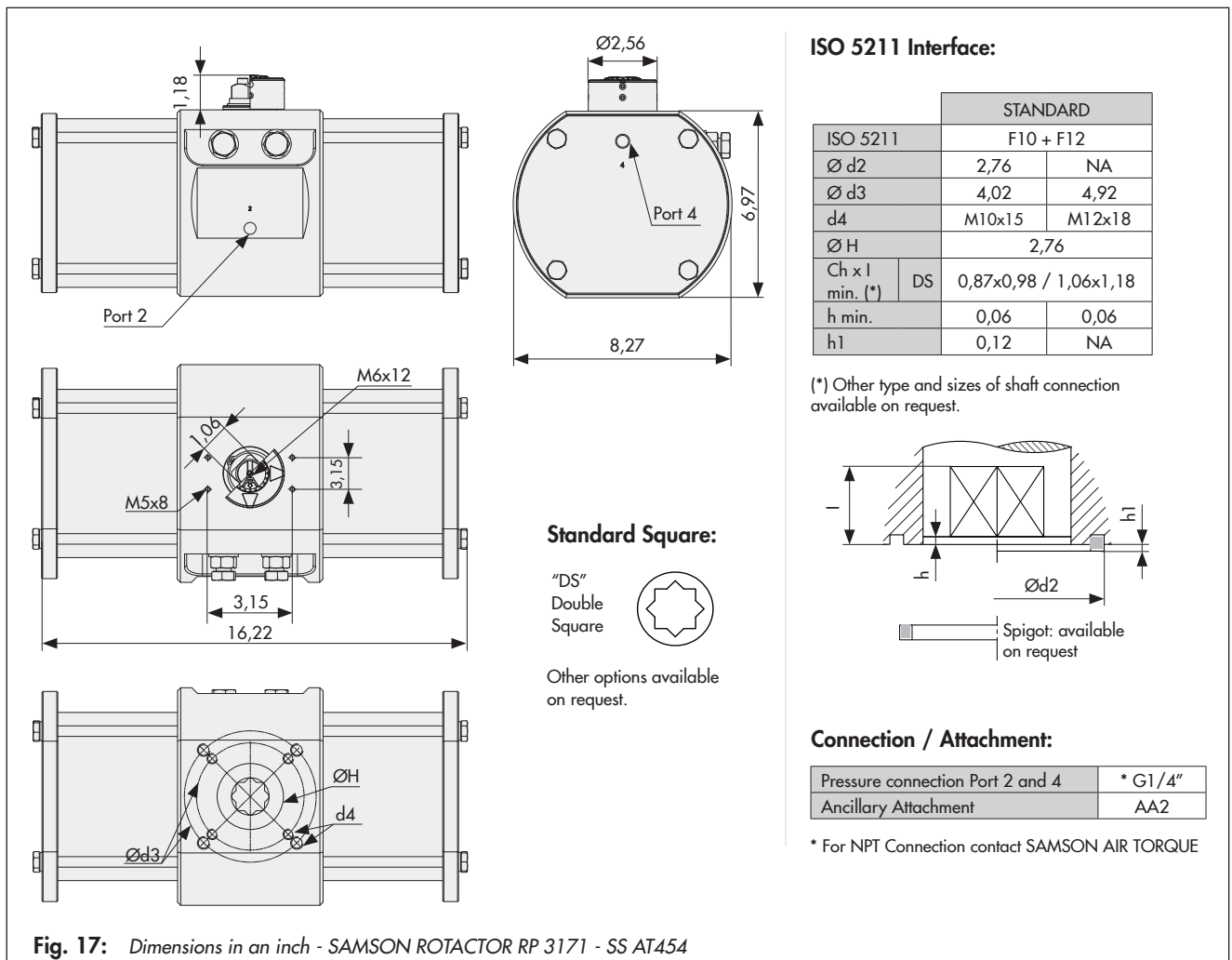

Fig. 17: Dimensions in an inch - SAMSON ROTACTOR RP 3171 - SS AT454

Table 8: SAMSON ROTACTOR RP 3171 - SS AT554

Table 8.1: Technical data

Max. Pressure	Standard Rotation	Stroke Adjustment Screw	Ø Chamber (in)	Air volume (in ³)		Approx. Stroking time (sec.) ¹⁾				Operating temperature range (°F) ²⁾		
						Double acting		Spring return				
116 Psi	0° - 90°	For 1° adj. 1/4 Turn needed	7,09	opening	closing	opening	closing	opening	closing	ST	HT	LLT2
				260	420	2,0	2,2	2,4	2,8	-40 to +176	+5 to +302	-76 to +176

¹⁾ The values refer to specific test conditions; please contact SAMSON for detailed information.

²⁾ Every temperature range option requires proper components and lubricant. please contact SAMSON for detailed information.

Table 8.2: Nominal output torque for Double acting actuators (lb-in)

Pres- sure	40 Psi		50 Psi		60 Psi		70 Psi		80 Psi		90 Psi		100 Psi		110 Psi		116 Psi		Approx weight (lb)
	0°	90°	0°	90°	0°	90°	0°	90°	0°	90°	0°	90°	0°	90°	0°	90°	0°	90°	
D	3739		4674		5609		6544		7479		8413		9348		10283		10844		128

Table 8.3: Nominal output torque for Single acting actuators (lb-in)

Pressure	40 Psi		50 Psi		60 Psi		70 Psi		80 Psi		90 Psi		100 Psi		110 Psi		116 Psi		Spring Stroke	Approx weight (lb)	
	0°	90°	0°	90°	0°	90°	0°	90°	0°	90°	0°	90°	0°	90°	0°	90°	0°	90°			
S 05	2340	1644	3275	2578	4210	3513	5145	4448	6079	5383	7014	6318	7949	7253					2096	1399	135
S 06	2060	1225	2995	2159	3930	3094	4865	4029	5800	4964	6734	5899	7669	6833	8604	7768			2515	1679	
S 07	1780	805	2715	1740	3650	2675	4585	3610	5520	4545	6454	5480	7389	6414	8324	7349	8885	7910	2934	1959	137
S 08			2435	1321	3370	2256	4305	3191	5240	4126	6175	5060	7109	5995	8044	6930	8605	7491	3353	2239	
S 09					3090	1837	4025	2772	4960	3706	5895	4641	6830	5576	7764	6511	8325	7072	3772	2519	139
S 10							3745	2353	4680	3287	5615	4222	6550	5157	7485	6092	8045	6653	4191	2798	
S 11									4400	2868	5335	3803	6270	4738	7205	5673	7766	6234	4610	3078	142
S 12													5990	4319	6925	5254	7486	5814	5029	3358	

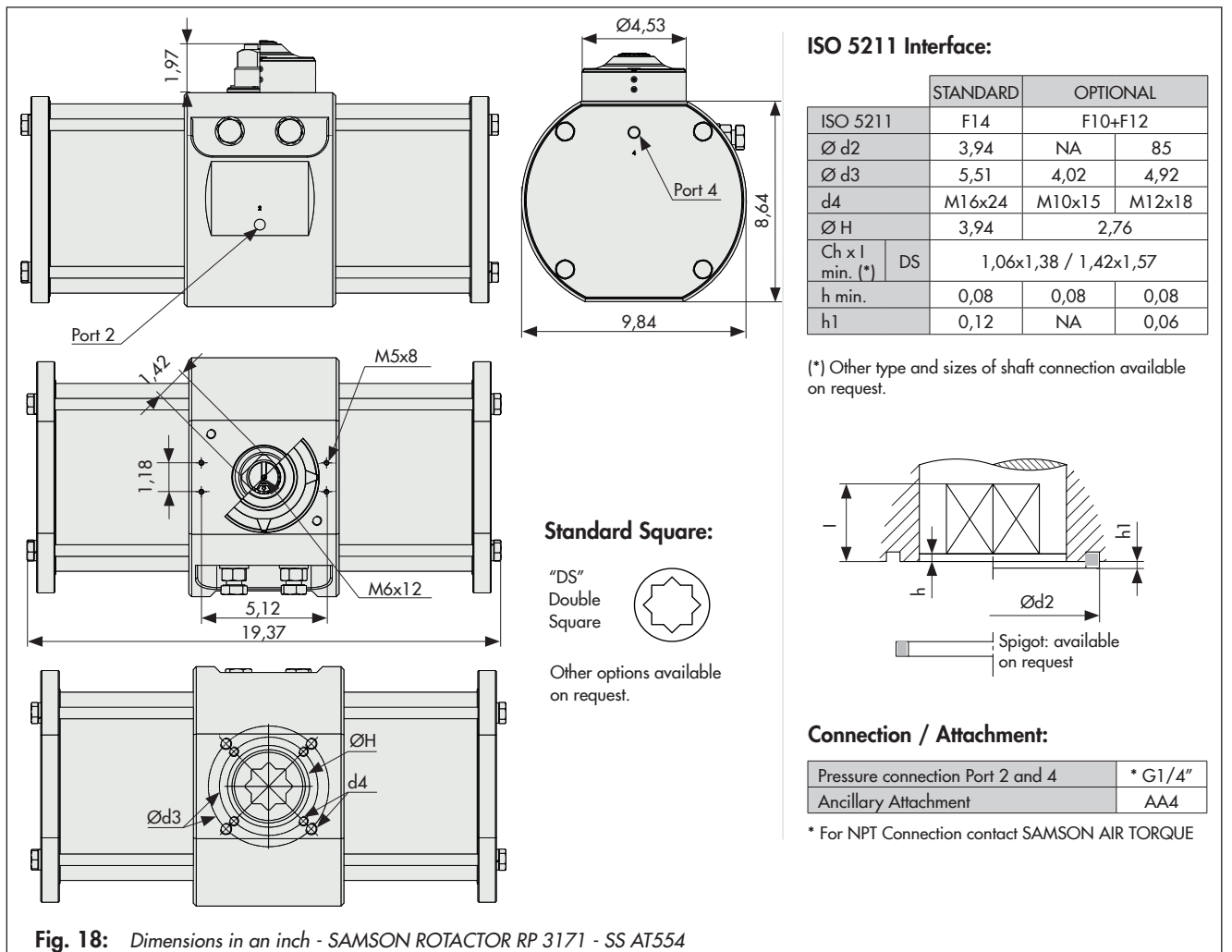

Fig. 18: Dimensions in an inch - SAMSON ROTACTOR RP 3171 - SS AT554

Table 9: SAMSON ROTACTOR RP 3171 - SS AT654

Table 9.1: Technical data

Max. Pressure	Standard Rotation	Stroke Adjustment Screw	Ø Chamber (in)	Air volume (in ³)		Approx. Stroking time (sec.) ¹⁾				Operating temperature range (°F) ²⁾		
						Double acting		Spring return				
116 Psi	0° - 90°	For 1° adj. 1/4 Turn needed	9,45	opening	closing	opening	closing	opening	closing	ST	HT	LLT2
				610	928	3,5	4,0	4,1	4,6	-40 to +176	+5 to +302	-76 to +176

¹⁾ The values refer to specific test conditions; please contact SAMSON for detailed information.

²⁾ Every temperature range option requires proper components and lubricant. please contact SAMSON for detailed information.

Table 9.2: Nominal output torque for Double acting actuators (lb-in)

Pressure	40 Psi		50 Psi		60 Psi		70 Psi		80 Psi		90 Psi		100 Psi		110 Psi		116 Psi		Approx weight (lb)
	0°	90°	0°	90°	0°	90°	0°	90°	0°	90°	0°	90°	0°	90°	0°	90°	0°	90°	
D	8725		10906		13087		5269		17450		19631		21812		23994		25302		275

Table 9.3: Nominal output torque for Single acting actuators (lb-in)

Pressure Spring Set	40 Psi		50 Psi		60 Psi		70 Psi		80 Psi		90 Psi		100 Psi		110 Psi		116 Psi		Spring Stroke	Approx weight (lb)	
	0°	90°	0°	90°	0°	90°	0°	90°	0°	90°	0°	90°	0°	90°	0°	90°	0°	90°			
S 05	5535	4113	7716	6294	9898	8475	12079	10657	14260	12838	16441	15019	18623	17200					4612	3190	290
S 06	4897	3190	7078	5372	9260	7553	11441	9734	13622	11915	15803	14097	17985	16278	20166	18459			5534	3828	
S 07	4259	2268	6440	4449	8622	6631	10803	8812	12984	10993	15165	13174	17347	15356	19528	17537	20837	18845	6457	4466	295
S 08			5802	3527	7984	5708	10165	7889	12346	10071	14527	12252	16709	14433	18890	16614	20199	17923	7379	5104	
S 09					7346	4786	9527	6967	11708	9148	13889	11329	16071	13511	18252	15692	19561	17001	8302	5742	300
S 10							8889	6045	11070	8226	13251	10407	15433	12588	17614	14770	18923	16078	9224	6380	
S 11									10432	7303	12613	9485	14795	11666	16976	13847	18285	15156	10147	7018	306
S 12													14157	10743	16338	12925	17647	14233	11069	7656	

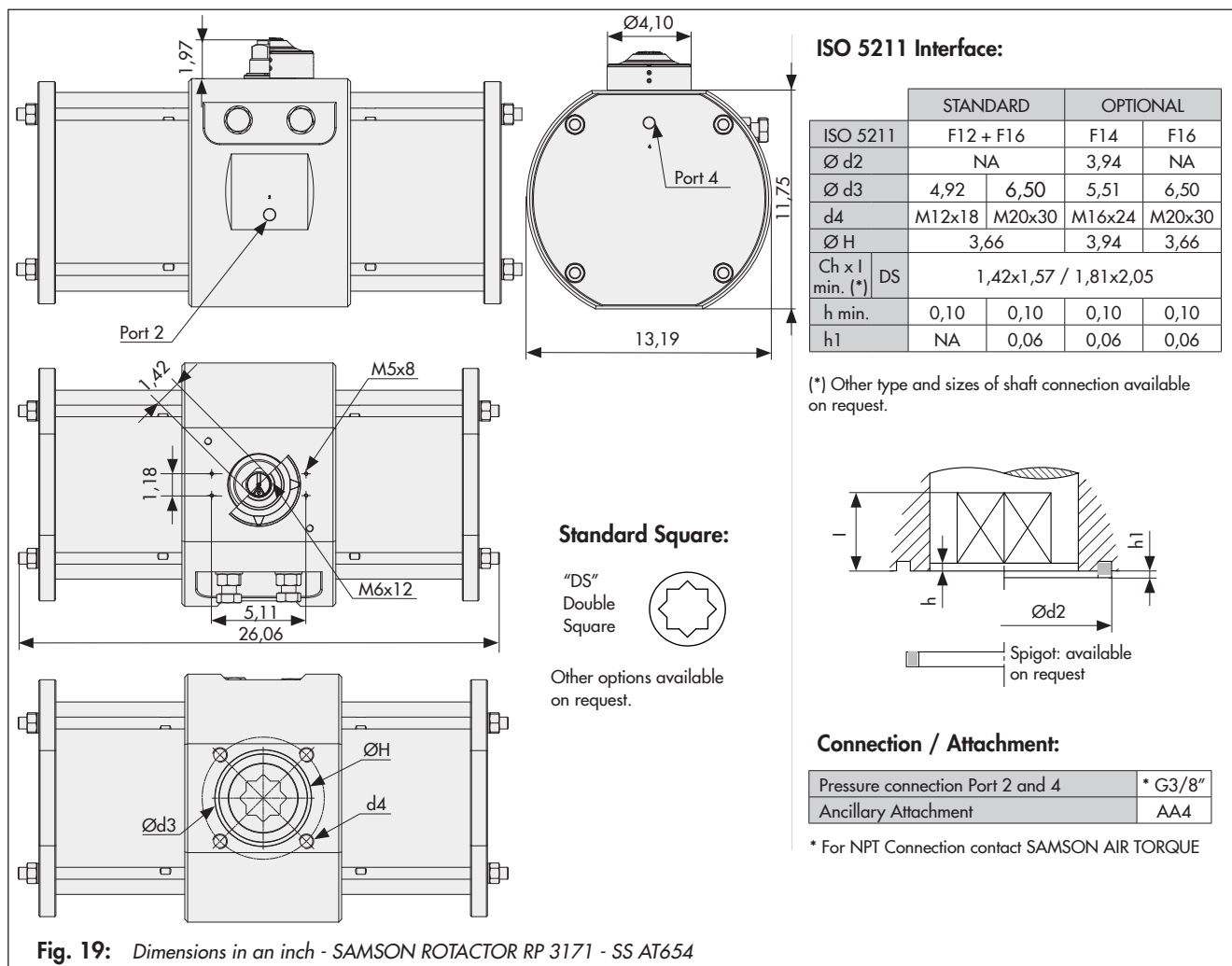

Fig. 19: Dimensions in an inch - SAMSON ROTACTOR RP 3171 - SS AT654

Complete Spare parts

• Parts list and quantity

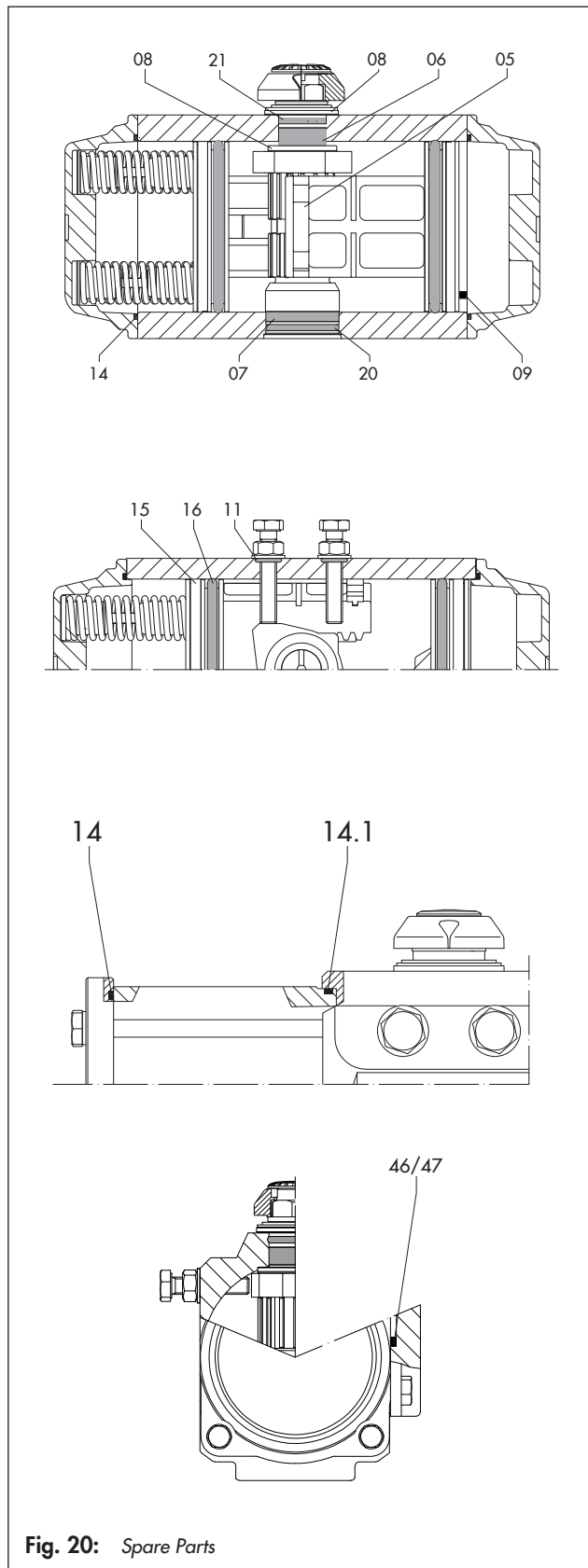

Fig. 20: Spare Parts

Complete Spare Parts		
Part n°	Q.ty	Description
05	2	BEARING (Piston back)
06	1	BEARING (Pinion top)
07	1	BEARING (Pinion bottom)
08	2	THRUST BEARING (Pinion)
09	2	PLUG for AT054U → AT404 models
11	2	"O" RING (Stop screw)
14	2	"O" RING (End cap)
14.1	2	"O" RING (Body extensions) for "S" AT454 → "S" AT654 models
15	2	BEARING (Piston head)
16	2	"O" RING (Piston)
20	1	"O" RING (Pinion bottom)
21	1	"O" RING (Pinion top)
46	1	"O" RING Port 2 (Connection plate) for "S" AT054U → "S" AT404 models
47	1	"O" RING Port 4 (Connection plate) for "S" AT054U → "S" AT404 models

SAMSON lubricant grease type			
Operating temperature	ST	LLT2	HT
Lubricant code	GSTD	GLLT2	GHT

• Spare Parts kits code

Actuator model	Operating Temperature Range Options		
	STANDARD kits code from -40°C (-40°F) to +80°C (+176°F)	LLT2 kits code from -60°C (-76°F) to +80°C (+176°F)	HT kits code from -15°C (5°F) to +150°C (+302°F)
SS AT054U	CRK-SS050#SPN..C	CRK-SS050#LLSPSC	CRK-SS050#HSPFC
SS AT104	CRK-SS100#SPN..C	CRK-SS100#LLSPSC	CRK-SS100#HSPFC
SS AT204	CRK-SS200#SPN..C	CRK-SS200#LLSPSC	CRK-SS200#HSPFC
SS AT254	CRK-SS250#SPN..C	CRK-SS250#LLSPSC	CRK-SS250#HSPFC
SS AT304	CRK-SS300#SPN..C	CRK-SS300#LLSPSC	CRK-SS300#HSPFC
SS AT404	CRK-SS400#SPN..C	CRK-SS400#LLSPSC	CRK-SS400#HSPFC
SS AT454	CRK-SS450#SPN..C	CRK-SS450#LLSPSC	CRK-SS450#HSPFC
SS AT554	CRK-SS550#SPN..C	CRK-SS550#LLSPSC	CRK-SS550#HSPFC
SS AT654	CRK-SS650#SPN..C	CRK-SS650#LLSPSC	CRK-SS650#HSPFC

For maintenance and/or spare parts refer to applicable EB 8326-1 SAMSON manual instruction.

Ordering text

The product information in the How To Order are transferred in the product label and in other SAMSON documents (as order acknowledgment, packing list, invoice and certificates). The position of the information can change respect the How To Order. Contact SAMSON for further details.

1	SAMSON ROTACTOR RP 3171 actuator models:		SB AT054U to SB AT654: standard material and surface finishing, with ENP coating SBP AT054U to SBP AT654: standard material and polished surface with ENP coating SC AT054U to SC AT654: standard material and surface finishing, with NO ENP coating SCP AT054U to SCP AT654: standard material and polished surface, with NO ENP coating							
2	D: Double Acting					S: Single Acting				
3	Actuator model, series and rotation: 90° Rotation (Standard): SB AT054U to SB AT654					Other Rotation evaluated on request.				
4	(Blank): for Standard actuator					R50: 50% opening travel stop limitation (45° up to 90°) R100: 100% opening travel stop limitation (0° up to 90°)				
5	(Blank): for standard actuator					FA: fast acting				
6	(Blank): for standard lock-out capability version									
7	Double acting actuators					Spring return actuators				
	(Blank)					SB AT054U Spring Set configuration: S1 / S2 / S3 / S4 / S5 / S6 / S7 / S8			SB AT104 → SB AT654 Number of Spring: 05 to 12 spring for standard 90° rotation	
8	ISO 5211 Flange									
	Model	SB AT054U	SB AT104	SB AT204	SB AT254	SB AT304	SB AT404	SB AT454	SB AT554	SB AT654
	Standard	F04	F05	F05 + F07	F05 + F07	F05 + F07 + F10	F07 + F10	F10 + F12	F14	F12 + F16
Options	F03	-	-	-	-	-	-	F10 + F12	F14	F16
9	N: air connection threads according to ANSI B1.20.1 (NPT). <i>Note: For SB AT454 and bigger contact SAMSON AIR TORQUE</i>									
10	(Blank): no spigot					Y: spigot				
11	(Blank) actuator with standard seals suitable for -40°C (-40°F) to +80°C (+176°C)			HT: actuator construction suitable for -15°C (+5°F) to +150°C (+302°F)			LLT 2: construction suitable for -60°C (-76°F) to +80°C (+176°F)			
12	Standard (DS): XXDS					Optional connections: (available on request) S x d (D) → flat head dimensions W x d → double keys dimensions XXD → diagonal single square XXL → parallel single square				
	Available square dimensions and type (according to ISO 5211)									
	Model	SB AT054U	SB AT104	SB AT204	SB AT254	SB AT304	SB AT404	SB AT454	SB AT554	SB AT654
ISO Flange	0,35DS 0,43DS	0,43DS 0,55DS	0,55DS 0,67DS	0,67DS	0,67DS 0,87DS	0,87DS 1,06DS	0,87DS 1,06DS	1,06DS 1,42DS	1,42DS 1,81DS	
13	Position Indicator: MF (multifunction indicator)									
14	Actuator assembly type									
	(Blank): Standard assembly type ST, clockwise to close (spring to close) and close indication at air failure condition (or with pressurized port 4 for double acting) for in line mounting.			LF: Counterclockwise to close (spring to open) and open indication at air failure condition (or with pressurized port 4 for double acting) for across line mounting.			STR: Clockwise to close (spring to close) and close indication at air failure condition (or with pressurized port 4 for double acting) for across line mounting.		LFR: Counterclockwise to close (spring to open) and open indication at air failure condition (or with pressurized port 4 for double acting) for in line mounting.	

Examples of model designation

1	2	3	4	5	6	7	8	9	10	11	12	13	14
SB AT204	S	90°	R100	FA	-	12	F05+F07	N	-	LLT2	14DS	MF	-
PNEUMATIC ACTUATOR model SB AT204 , Spring Return S , rotation 90° , R100 travel stop adjustment, FA Fast Acting, - lockout capability version, number of spring 12 , ISO flange F05+F07 , NPT air connection N , without spigot, low operating temperature HT , Ch14 double square drive shaft 14DS , Black Multifunction indicator MF , Standard assembly type ST REFER TO TECHNICAL DATA SHEETS FOR UPDATED DIMENSIONS AND MATERIALS.													